

The Vermont Residential Building Energy Standards



Vermont Residential Building Standards (RBES)

Energy Code Handbook

*A Guide to Complying with
Vermont's Residential Building Energy Standards (30 V.S.A. § 51)*

FIFTH EDITION

Base & Stretch Energy Code Effective July 1, 2024

Energy Code Assistance Center
20 Winooski Falls Way, 5th Floor

Winooski, Vermont 05404

855-887-0673 ~ toll free

Vermont Public Service Department
Efficiency & Energy Resources Division

112 State Street

Montpelier, VT 05620-2601

802-828-2811



This publication was prepared with the support of the U.S. Department of Energy.

DRAFT

Contents

| | | |
|----------------------|--|-----------|
| | How to Use This Handbook | 6 |
| | When to Consult the Handbook | 6 |
| | Overview | 6 |
| | What's New in RBES 2020? | 6 |
| | If You Need Help | 8 |
| Introduction: | The Vermont Residential Standards (RBES) Energy Code | 10 |
| | What Buildings Must Comply? | 10 |
| | What Buildings Are Exempt? | 10 |
| | The Basic Steps for Meeting the Energy Code | 11 |
| | Compliance Methods | 11 |
| | Stretch Code | 12 |
| | Technical Assistance with Energy Code Requirements | 12 |
| | Residential Energy Code Updates | 12 |
| Chapter 1: | Rules for Compliance | 13 |
| | 1.1 Builder's Responsibilities | 13 |
| | 1.2 Buildings That Must Comply | 13 |
| | 1.3 Exempt Buildings | 14 |
| | 1.4 Owner/Builder Special Provision | 14 |
| | 1.5 Act 250 Provisions | 15 |
| | 1.6 Penalty for Not Complying with the Residential Energy Code | 15 |
| Chapter 2: | Moisture Management for Durable Buildings | 16 |
| | 2.1 Introduction | 16 |
| | 2.2 Water Risk Management | 17 |
| | 2.3 Assembly Examples | 30 |
| | 2.4 Resources | 45 |
| Chapter 3 : | Basic Requirements | 45 |
| | 3.1 Building Envelope | 47 |
| | 3.2 Unvented Attics | 53 |
| | 3.3 Materials and Equipment Information | 53 |
| | 3.4 Vapor Retarders | 55 |
| | 3.5 Heating and Cooling | 56 |
| | 3.6 Water Heating | 58 |
| | 3.7 Electrical | 59 |
| | 3.8 Lighting | 60 |
| | 3.9 Electric Vehicle Charging | 60 |

| | | |
|-------------|--|-----|
| Chapter 4 : | Ventilation and Combustion Safety Requirements | 62 |
| | 4.1 Ventilation. | 62 |
| | 4.2 Combustion Safety | 69 |
| Chapter 5 : | Existing Homes: Additions, Alterations and Repairs | 73 |
| | 5.1 Exceptions..... | 74 |
| | 5.2 Compliances | 76 |
| | 5.3 Prescriptive Compliance for Additions | 76 |
| | 5.4 U-Factor and UA Alternative Compliance for Additions..... | 78 |
| Chapter 6 : | The Package-Plus-Points Compliance Method..... | 80 |
| | 6.1 When to Use the Package-Plus-Points Compliance Method..... | 80 |
| | 6.2 Meeting Base and Stretch Code Using the Package-Plus-Points Method . | 82 |
| | 6.3 Tiny House Standards..... | 89 |
| Chapter 7 : | The REScheck™ Software Compliance Method..... | 91 |
| | 7.1 How the REScheck™ Compliance Method Works..... | 92 |
| | 7.2 Using the REScheck™ Software..... | 92 |
| | 7.3 How to Obtain the REScheck™ Software..... | 93 |
| Chapter 8 : | The Home Energy Rating Compliance Method | 94 |
| | 8.1 How the Home Energy Rating Compliance Method Works..... | 94 |
| | 8.2 Advantages of the Home Energy Rating Compliance Method | 95 |
| | 8.3 The Home Energy Rating..... | 96 |
| | 8.4 Minimum Thermal Envelope Efficiency Levels for HERS Compliance | 96 |
| | 8.5 The HERS Compliance Process..... | 98 |
| Chapter 9 : | Certification | 99 |
| | 9.1 Types of Certification | 99 |
| | 9.2 The Vermont Residential Building Energy Standards Certificate..... | 99 |
| | 9.3 The Vermont ‘Owner-Builder Disclosure Statement..... | 105 |
| Appendix A: | Additional Stretch Code Requirements..... | 110 |
| | A.1 Package Plus Points..... | 110 |
| | A.2 Home Energy Rating Compliance Method..... | 110 |
| | A.3 Air Leakage Testing..... | 110 |
| | A.4 Electric Vehicle (EV) Charging | 111 |
| | A.5 Solar Ready Zone | 111 |
| | A.5a Construction Document Requirements for Solar Ready Zone | 112 |
| | A.5b Solar-Ready Zone Area | 112 |
| | A.5c Obstructions..... | 112 |
| | A.5d Roof Load Documentation..... | 112 |
| | A.5e Interconnection Pathway | 113 |
| | A.5f Electrical Service Reserved Space | 113 |
| | A.5g Electrical Energy Storage System-Ready Area..... | 113 |
| Appendix B: | Default Values | 114 |
| Appendix C: | Guidelines for Calculations | 115 |

| | |
|---|-----|
| C.1 When to Perform Calculations..... | 115 |
| C.2 How to Define the Building Envelope | 115 |
| C.3 Understanding Thermal Values | 117 |
| C.4 How to Calculate Average R-values and U-factors..... | 117 |
| Appendix D: Cavity-Only Wall Insulation Exception: Examples | 120 |
| Appendix E: Vermont Resources for Energy Efficiency and Utility Services... | 122 |
| Appendix F: Residential Building Energy Standards Statute | 124 |
| Appendix G: Definitions | 125 |

DRAFT

The Vermont Residential Building Energy Standards

How to Use This Handbook

This Handbook contains information explaining the key requirements of Vermont’s “Residential Building Energy Standards” (“RBES” or the “Energy Code”) for residential construction. Each chapter is divided into sections. For instance, a reference to “Section 2.3” indicates the third section of Chapter 2. Further divisions of a section are labeled with a letter (e.g., 2.3a, 2.3b, etc.). Tables and figures are numbered sequentially within each chapter. For example, the first table in Chapter 3 is Table 3-1, the second table is Table 3-2, etc.

This Handbook also includes references to sections in the RBES code book. For a free viewable copy of the full RBES, visit <https://publicservice.vermont.gov/content/building-energy-standards>. A printed copy can be obtained by calling the Energy Code Assistance Center at 855-887-0673, toll free.

When to Consult the Handbook

There are four main situations that call for a review of this Handbook:

1. When making additions, alterations, renovations or repairs to existing homes.
2. Before starting a new construction project, review the RBES requirements during the design stage. It will be easier and less expensive at this stage to make any modifications needed to ensure compliance.
3. In the event of new construction design changes, review whether the home still complies with those changes. This will ensure that there are no surprises upon completion.
4. Upon completion, State law requires every Vermont builder to certify that the home complies with the Energy Code as built, altered or repaired.

New for this version of the RBES Energy Code Handbook is Chapter 2, Moisture Management for Durable Buildings. This new chapter addresses building in a Vermont climate to minimize the impacts of moisture and prolong building durability. It also consolidates the details and drawings that were scattered throughout previous versions of this Handbook to show all the “applications” of the Energy Code in one chapter.



What’s New in RBES 2024?

Major changes from RBES 2020 include but are not limited to:

1. Multifamily alignment
2. Combined and simplified packages
3. Thermal envelope improvements with U-factor focus
4. Adjust points table based on house size, multifamily
5. Added additional options for points
6. Balanced whole-house ventilation system
7. Electrification
 - a. Electric Vehicles (EV) capable
 - b. Solar Ready
 - c. Electric service panel sized for electrification
8. Tiny House standards
9. Definitions updated
10. New specific measures
 - a. LED lighting and lighting controls
 - b. Air-sealed electrical boxes
 - c. Ducts inside the building envelope
 - d. Electric meter for every unit
11. Home Energy Rating System (HERS) improved ratings and more tools
12. Embodied Carbon
13. Clarified Additions and Alterations
14. Updated Reference Standards

DRAFT

The Vermont Residential Building Energy Standards

- ✓ Introduction: Vermont Residential Building Energy Standards — summarizes the key features of the Energy Code.
- ✓ Chapter 1: Rules for Compliance — explains in detail which buildings must comply and which are exempt.
- ✓ Chapter 2: Moisture Management for Durable Buildings— provides an overview of Vermont-appropriate construction approaches to minimize moisture issues and prolong building durability. Includes drawings and details of building components for code-compliant and low-risk options.
- ✓ Chapter 3: Basic Requirements — explains in detail the mandatory requirements that all buildings must meet (aside from additional Prescriptive or Performance requirements).
- ✓ Chapter 4: Ventilation and Combustion Safety Requirements — discusses the importance of combustion safety and indoor air quality and how to achieve both.
- ✓ Chapter 5: Existing Homes: Additions, Alterations, and Repairs — explains code requirements for additions, alterations and repairs.
- ✓ Chapter 6: The Package Plus Points Compliance Method — explains how to meet the Energy Code via the Package Plus Points compliance pathway. This method is similar to the Prescriptive Compliance Method from previous code cycles but with key changes.
- ✓ Chapter 7: The REScheck™ Software Compliance Method — explains how REScheck™ can be used to check for compliance.
- ✓ Chapter 8: The Home Energy Rating Compliance Method — explains how Energy Rating Index or Home Energy Rating System (“ERI” or “HERS”) can be used for compliance.
- ✓ Chapter 9: Certification — specifies how to accurately certify compliance with the Energy Code.

The **Appendices** include the minimum requirements for Stretch code, definitions and clarifications of terms used in this Handbook, default R-values and U-factors, guidelines for calculations, and Vermont-specific resources for builders.

If You Need Help

The Energy Code Assistance Center (ECAC) provides free technical assistance. Call toll-free: 855-887-0673.

DRAFT

• This chapter summarizes the key features of the Vermont Residential Building Energy Code on July 1, 2024.

The Vermont Residential Building Energy Standards (RBES) Energy Code

The Vermont Residential Building Energy Standards (“RBES”, the “Residential Energy Code” or simply the “Energy Code”) initially was passed by the Vermont legislature in May 1997. It is a minimum standard of energy efficiency that has applied to virtually all new residential construction in Vermont since July 1, 1998 with updates in 2006, 2011, 2015, 2020, and 2024. The 2024 Energy Code builds upon the 2020 Vermont Residential Building Energy Standards, which are based on the International Energy Conservation Code® (IECC). The 2024 RBES also includes select IECC 2021 and 2024 updates with modified Vermont energy efficiency requirements.

What Buildings Must Comply?

- ★ New detached one- and two-family dwellings.
- ★ New multifamily and all other residential dwellings three stories or fewer in height.
- ★ Additions, alterations, renovations and repairs to existing residential buildings.
- ★ Factory-built modular homes not on a permanent chassis.
- ★ Residential buildings commencing construction on or after July 1, 2024 must comply with this Energy Code. Residential buildings for which construction commenced before July 1, 2024, if not complying with this Code, must comply with the previous version of RBES.
- ★ Act 250 projects commencing construction on or after July 1, 2024 must comply with the 2024 Stretch Code.
- ★ In towns that require a certificate of occupancy (COO), an RBES certificate is required before the COO can be issued.

This is a summary; see Chapter 1 for details.

What Buildings Are Exempt?

- ★ Commercial and high-rise residential buildings (over three stories). However, these must meet the Commercial Building Energy Standards (“CBES”). Residential portions of a mixed-use building that is three stories or less must meet the Residential Energy Code. Residential portions of mixed-use buildings include the living spaces in the building and the nonliving spaces in the building that serve only the residential users such as common hallways, laundry facilities, residential management offices, community rooms, storage rooms, and foyers. Many aspects of both RBES and CBES were aligned in the 2024 versions of both codes.
- ★ Mobile homes on a permanent chassis (except for site-built components such as conditioned basements or crawl spaces).
- ★ Buildings or additions with very low energy use (those designed for a peak energy use of less than 3.4 Btu/hr. per square foot of floor area).
- ★ Unconditioned buildings.
- ★ Hunting camps or summer camps. Note that summer camps are only exempt if constructed for non-winter occupation with only a biomass (wood) or other on-site renewable heating system.
- ★ Yurts with only a biomass (wood) or other on-site renewable heating and hot water system.
- ★ Tiny Houses. While not specifically exempt, tiny houses must comply with specific envelope, insulation and fenestration requirements along with all other code provisions with the exception that the mechanical ventilation system may be exhaust-only. (See Section 4.1a)
- ★ Individual provisions of the code may be exempted when applied to historic buildings if the provision would threaten, degrade or destroy the historic form, fabric or function of the building. (See Chapter 5)

This is a summary; see Chapter 1 for details.

The Basic Steps for Meeting the Code

The Vermont Residential Energy Code encompasses two requirements:

- 1) A **technical requirement** (i.e., minimum standards for energy-efficient building components and construction practices) and
- 2) A **certification requirement** for reporting compliance. It is one of the few energy codes in the **country in which the builder may self-certify compliance.**

The law recognizes that it is the builder's responsibility to understand the Residential Energy Code, to build to the minimum technical efficiency standards, and then to certify (on a two-page form) that the building complies with the law. Plan reviews or final inspections may be required by local building code officials¹. However, a blower door air leakage test by a certified inspector is now required for all homes. The whole code compliance process can be summarized as follows:

1. Determine whether you need to comply (Chapter 1);
2. Understand the building science that will help you construct assemblies designed for Vermont's climate while minimizing future building failures (Chapter 2 and trainings);
3. Follow the Basic Requirements (Chapter 3);
4. Follow the minimum Ventilation and Combustion Safety Requirements (Chapter 4);
5. For existing homes, follow the requirements for additions, alterations and repairs (Chapter 5).
6. Select and complete the Compliance Method that works best for you, complete a blower door air leakage test (Chapters 6-8); and
7. Fill out, file and post the required compliance certificate (Chapter 9).

Compliance Methods

In order to comply with the Residential Energy Code, a home as built must meet all the Basic Requirements, Ventilation & Combustion Safety Requirements and the Prescribed Requirements using one of the compliance methods. Additions, alterations and repairs must meet the Existing Homes requirements pertaining to the portion(s) of the home affected.

The Energy Code is both simple and flexible in the ways a home can meet the technical requirements. There are three methods that can be used to comply. You select the one that works best for your design. There are three options that describe the thermal and efficiency values that are necessary to meet the minimum standards of the Energy Code. These vary in simplicity of use, as well as in the level of efficiency above the minimum standards that must be achieved. In general, the simplest methods specify the highest levels of efficiency, while the more complex methods are closest to the minimum efficiency standard of the Energy Code. The three compliance methods are:

| | |
|---------------------------|--|
| Prescriptive Method | The simplest approach. The "Package Plus Points" approach allows you to incorporate a prescribed set of features with minimal calculations. (See Chapter 6.) |
| REScheck™ Software Method | Use your computer with REScheck™ software to easily analyze almost any design and determine whether any modifications are needed to meet the Base Code. This method cannot be used for Stretch Code compliance. (See Chapter 7.) |
| Home Energy Rating Method | This approach gives full credit for airtightness, efficient heating, cooling and domestic water heating, and solar orientation. A certified Energy Rater is required to complete this approach. (See Chapter 8.) |

¹ While the Residential Energy Code does not require inspections by code officials, it does not eliminate inspections related to Act 250 projects, spot checks for enforcement of other applicable codes, or inspections required by state or local codes.

The Residential Energy Code is both simple and flexible in the ways a home can meet the technical requirement. There are three methods that can be used to comply. You select the one that works best for your design.

Stretch Code

The Residential Energy Code includes two levels of stringency: Base Code and Stretch Code. The Base Code is the standard level most everyone must meet (see “Which Buildings Must Comply” above). The Stretch Code is the required level for all Act 250 projects and in Vermont towns that choose to implement a higher energy standard. In general, the Stretch Code includes the following:

- ★ Requirements for installing a “solar ready zone” that is optional for Base Code; and
- ★ Higher points requirement to achieve compliance (see Table 6-5 Required Points by Building Size for Stretch Code and Table 6-6 Points Options for Stretch Code by Component)

Technical Assistance with Energy Code Requirements

Technical assistance with the Residential Energy Code is available at no charge. Contact the Energy Code Assistance Center (ECAC) at 855-887-0673 (toll free). ECAC services include:

- Workshops for builders on how to comply with the Vermont Residential Energy Code.
- Handbooks, forms, software and other Energy Code-related materials.
- Professional advice on how to easily meet the Energy Code.
- Information about state-of-the-art construction techniques and building details.
- Referral to energy-efficiency programs.
- Sources for energy-efficient products.
- Customized workshops and presentations on energy-efficient building practices.

Residential Energy Code Updates

The statute that governs the Vermont Residential Energy Code provides for regular review and updates to the provisions in the Energy Code. The review of the Residential Energy Code is administered by the Vermont Department of Public Service (PSD). Please address all comments and inquiries to:

Vermont Public Service Department
Efficiency & Energy Resources Division
112 State Street
Montpelier, Vermont 05620-2601
802-828-2811

E-CALL Hotline

855-887-0673

The E-CALL Hotline is staffed from 8 a.m. to 5 p.m. Monday through Friday. A voice mail is available at all other times. Call for free assistance with any Code-related questions or concerns you may have.

Energy Code 
Assistance Center

This chapter discusses:

- ★ The builder's responsibilities under the Vermont Residential Energy Code.
- ★ What the Residential Energy Code does and does not cover.

Chapter 1

Rules for Compliance

Section 1.1

Builder's Responsibilities

Under the Vermont Residential Energy Code, it is your responsibility as a builder to determine *for each residential building project*:

1. Whether the building is required to meet the minimum technical requirements of the Energy Code, and
2. Whether an RBES Certificate must be completed and filed in order to meet certification requirements (a Certificate is **required** unless the building is exempt as specified in Section 1.3).

Section 1.2

Buildings That Must Comply

The following buildings must meet both the technical and the certification requirements of the Vermont Residential Energy Code:

- **Detached one- and two-family dwellings.**
- **Multifamily and other residential buildings three stories or fewer in height** and any residential portions of a mixed-use building 3 stories or fewer in height.
- **Additions, alterations and repairs** (further detail in Chapter 5).
- **Factory-built modular homes** not subject to Title VI of the National Manufactured Housing Construction & Safety Standards Act of 1974 (i.e., homes not on a permanent chassis).
- **Site built components** (such as conditioned basements or crawlspaces) of mobile homes not subject to RBES must comply.

Section 1.3

Exempt Buildings

The following buildings are exempt from both the technical and the certification requirements of the 2024 Vermont Residential Energy Code:

- **Commercial buildings**, portions classified as commercial, or high-rise residential (over three stories). These buildings must comply with the 2024 Commercial Building Energy Standards (CBES).
- **Mobile homes** subject to Title VI of the National Manufactured Housing Construction & Safety Standards Act of 1974 (i.e., single- and double-wide homes on a permanent chassis). Site-built components such as conditioned basements or crawlspaces are not exempt and must be constructed to meet the Residential Energy Code.
- **Buildings or additions with very low energy use**: Buildings or additions designed for a peak energy use of less than 3.4 Btu/h (1 Watt) per square foot of floor area. (Any occupied building intended to be heated and lived in will not meet this exemption.)
- **Unconditioned buildings** that are neither heated nor cooled.
- **Hunting camps and summer camps**. Note that summer camps are only exempt if constructed for non-winter occupation with *only* a biomass (wood) or other on-site renewable heating system.
- **Yurts** with only a biomass (wood) or other on-site renewable heating and hot water system.
- **Tiny Houses** (defined as a detached dwelling unit of less than 400 square feet of floor area excluding lofts), while not specifically exempt, must comply with the envelope, insulation and fenestration requirements in **Section 6.4**. All other code provisions are still required with the exception that the mechanical ventilation system does not have to be heat recovery with balanced ventilation and may be exhaust-only.
- Individual provisions of the code may be exempted when applied to historic buildings if the provision would threaten, degrade or destroy the historic form, fabric or function of the building. (See Chapter 5)
- Unaltered portions of an existing building or building system do not need to comply.

Section 1.4

Owner/Builder Special Provision

“Owner/builder” projects are exempt from the technical requirements of the Code, but the owner/builder must meet certification requirements by completing and filing a *Vermont Owner/ Builder Disclosure Statement* at the Town Clerk’s Office where the home is located and with the Vermont Public Service Department. To qualify for this provision, *all* of the following criteria must be met:

1. The owner must be the person in charge of construction (i.e., the “general contractor”), directing the details of construction and the selection and installation of materials.
2. The owner must live in the building.
3. The owner must evaluate whether the home meets the Residential Energy Code.
4. Depending on whether the home meets the technical requirement of the Energy Code, the owner must complete one of two documents: either the *Vermont Residential Building Energy Standards Certificate* if the home meets the technical requirement, or the *Vermont Owner/ Builder Disclosure Statement* if it does not. (See Chapter 9.)
5. Before entering into a binding purchase and sale agreement, the owner must disclose in writing (using the *Vermont Owner/Builder Disclosure Statement*) to a prospective buyer the nature and extent of any non-compliance with the Residential Energy Code.

Section 1.5

Act 250 Provision

Residential buildings commencing construction on or after July 1, 2024 must comply with this 2024 Energy Code. Residential buildings for which construction commenced before July 1, 2024, if not complying with this Energy Code, must comply with the previous version of RBES (2020 RBES). Act 250 projects falling under the 2024 RBES must meet the stretch code provisions as described in Chapter 6.

Section 1.6

Penalty for Not Complying with the Residential Energy Code

If a home required by law to meet the RBES does not comply, a homeowner may seek damages in court within six years of occupancy or the filing of the required certification as noted in Section 1.1. (For details on the certification process, see Chapter 9.)

DRAFT

Chapter 2

Moisture Management for Durable Buildings

This is a new chapter for the 2024 Residential Energy Code. This chapter addresses building in a Vermont climate to minimize the impacts of moisture and prolong building durability. It also consolidates the details and drawings that were scattered throughout previous versions of this Handbook to show all the “applications” of the Energy Code in one chapter.

2.1 Introduction

As the thermal performance of our buildings improves with the progress of our energy code, the risk of moisture damage in our assemblies increases. Building durable, efficient enclosures that are at low risk for moisture damage requires an understanding of what the moisture risks are, and how to minimize them in the design and construction of our buildings.

There are four primary control layers to every building, shown in Table 2.1. This chapter focuses primarily on vapor and air control, as these are the least understood and most relevant to managing the moisture risks from increased levels of insulation in our buildings. The biggest moisture risks to manage in buildings are the bulk leakage of water, and condensation in wall and roof assemblies due to air leakage and water vapor diffusion. Air leakage and vapor diffusion through materials can transfer large amounts of vapor into assemblies, where the vapor can condense on cold surfaces such as roof and wall sheathing. The inappropriate use of vapor-impermeable materials can trap this vapor in assemblies and prevent the assemblies from drying out.

Table 2.1: Four Control Layers of a Building

| Control Layer | Function | Description |
|----------------------|---|--|
| Thermal Control | Slow unwanted conductive heat transfer | Insulation in-cavity, inboard, or outboard of the framing |
| Bulk Water Control | Keep liquid moisture from the air or ground from entering building assemblies | Roof underlayment, wall house wrap, foundation coatings, flashing connections |
| Pressure/Air Control | Reduce moisture transfer and heat loss through air leakage | Air barriers on the inner and/or outer planes of building assemblies, connected together |
| Vapor Control | Reduce vapor diffusing into the assembly | Vapor retarders typically on the inner planes of building assemblies |

To address these risks, good building design features proper bulk water control layers and flashing, air-tight construction, and drying pathways for vapor to leave building assemblies. Air-tight detailing between assemblies (e.g., wall-to-roof connections) can be difficult to achieve if not properly planned and should be carefully considered in design and construction. Ensuring the correct use of vapor retarders to allow drying to either the outside or inside of the assembly

is another important consideration. The use of roof venting can assist in allowing roof assemblies to dry.

It is easy in the design and construction of a building to separate out enclosure design from mechanicals. After all, these are two completely different focus areas, and their materials are installed and even designed by different people. However, buildings operate like a system, and it is important to design and build them like a system where the relationship between the different parts are understood and managed. This is especially true when it comes to managing moisture risk in building assemblies. Below is an example of how these complex relationships can impact the moisture risk to a building assembly:

When we increase the insulation levels in our walls and roofs more heat is kept inside the building in winter, resulting in increased comfort and less energy use. However, this makes the outer surfaces of the building assemblies colder for longer periods of time, which increases the condensation risk. Accordingly, the air tightness of our buildings must be increased to reduce the amount of vapor leaking into the assemblies that could condense on these cold surfaces. This also has the benefit of retaining the heat in the air, further improving comfort and thermal performance. Having increased the air tightness of building, it is now necessary to consider impacts on indoor air quality and the mechanical responses required to safeguard a healthy indoor environment. These include providing direct air supply for combustion and introducing balanced ventilation to ensure occupant health is preserved. These solutions also need to manage the humidity in the building, such as through range hoods and bathroom exhaust fans, to ensure occupant behaviors aren't contributing to the moisture risk of the assemblies by increasing the relative humidity in the home.

This chapter is not intended to be comprehensive, but rather a basic introduction to the core concepts required to build a durable building in compliance with the energy code. Additional resources for further learning are provided in *Section 2.4 Resources*, located at the end of the chapter for those seeking information beyond the basics. All moisture vapor control strategies rely on adequate indoor relative humidity control (e.g., mechanical ventilation), careful water-resistive barrier installation, and proper air-barrier installation practices (e.g., air-sealing the interior face of assemblies). An energy professional with experience in moisture management should be consulted for additional advice as needed, especially for abnormal conditions such as pool rooms, or where alternative materials and solutions are considered. Efficiency Vermont can provide resources for energy professionals to assist in keeping projects durable and code-compliant.

2.2 Water Risk Management

This section defines basic terms relating to water, water vapor and how moisture moves through building assemblies. Additionally, the materials in building assemblies designed to control moisture movement are identified, as well as how to develop strategies to create moisture-durable buildings. Examples of different building assemblies and discussion about their performance can be found in *Section 2.3 Assembly Examples*.

Water is the only substance on earth that exists in three phases under normal atmospheric conditions: solid (ice), liquid (water), and gas (water vapor, or humidity). The process of water changing from solid to liquid is called *melting* and is called *freezing* when changing from liquid to solid. Water *evaporates* changing from liquid to gas and *condenses* changing from gas to liquid. For the purposes of managing moisture risk in building assemblies, the phase change between liquid and gas is most important.

As water changes from a solid to a liquid, and liquid to gas, it absorbs energy. Moving the other direction, from gas to liquid to solid, energy is released. This is why humidity adds to cooling loads: when hot, humid air is cooled enough to condense the water vapor out of the air, this results in a significant release of *latent energy* that the cooling system must

manage in addition to the *sensible energy* of lowering the temperature of the air.¹

The topic of moisture management is vast, and this chapter is intended to introduce core concepts and definitions only. Please refer to *Section 2.4 Resources* for additional resources relating to this important topic.

2.2.1 Liquid Water Control

Liquid water can transfer through building materials and into and out of assemblies in several ways:

- Built-in moisture during construction: wet concrete, green lumber, joint compound. This moisture is introduced into an assembly via materials whose pores are full of water. This water must be dried out of the assembly through a vapor-permeable vapor control layer.
- Leaks: ground water through foundations, window leaks, roof leaks. This moisture is introduced from rain or snow events or from surface or ground water through failures in the building enclosure, either via gravity or through capillary action (see below). The bulk water control layer stops leaks through materials such as foundation waterproofing, window flashing, and roof underlayment.
- *Capillary action*, or “wicking”, through absorption in porous materials or gaps between materials: unsealed concrete to wooden sills, unsealed narrow gaps between windows and trim or framing. This moisture is introduced from a source of water into a material or from a saturated material to a dry material and can move upwards against gravity. Bulk water control layer materials such as waterproofing between footings and foundation walls, gaskets between foundation walls and wood sill plates, and caulking between windows and trim stop capillary action. Materials with large pore spaces can also stop capillary action, such as crushed stone above the water table adjacent to a concrete wall or slab.
- *Drainage*: the ability of liquid water to leave an assembly via gravity, such as in the plane behind cladding in a rainscreen system, or in a drained rough opening for a window. The drainage occurs outside of the bulk water control layer protecting the assembly within.
- Condensation from vapor entry and drying from evaporation (see *Section 2.2.2 Water Vapor Control*).

The biggest risk to building assemblies is through bulk water entry via leaks, poor flashing details, or other assembly failures. While condensation is a risk, prioritizing its management is secondary to ensuring a water-tight building assembly. Increasing insulation levels to meet code requirements may result in reduced drying potential due to reduced heat loss into the assembly. This means that leaks may take longer to dry out, increasing the potential for moisture damage.

The primary strategy to manage this risk is the appropriate installation of high-quality water-resistant barriers and underlayments in above-grade walls and roofs, as well as waterproofing and capillary breaks in below grade walls and slabs. For above-grade assemblies requiring outward drying, the permeance of these materials should be confirmed to ensure a vapor barrier is not inadvertently installed outside of the wall or roof sheathing. Installation instructions should be carefully read and followed for these products, as the installation details are critical and may not be intuitive or obvious for all applications².

Flashing details at assembly transitions, windows and doors, and penetrations are critical, and should be designed in advance to ensure the correct sequencing of materials is achieved. These details can vary significantly across different assembly types; for example, the window flashing for a thick wall assembly where the sheathing is close the exterior will

¹ Latent energy is the energy associated with a phase change such as water moving from a liquid to a gas and cannot be measured by a thermometer. Sensible energy is the energy that you can feel and the energy that is reflected in a temperature change on a thermostat.

² Additional information can be found in IRC R703 Exterior Covering (<https://codes.iccsafe.org/content/IRC2018/chapter-7-wall-covering>), where specific instructions are provided regarding choice and application of weather-resistant barriers.

be very different than for exterior continuous insulation where the sheathing is closer to the interior of the assembly. Careful planning and execution of these and related details is foundational to the durability of the building.³

Compatibility between different materials is another important consideration. Not all flashing tapes are compatible with all nailing flanges, and different caulks and sealants will have different compatibility with various substrates. Unless you are using a single barrier system from a single manufacturer, careful attention must be taken to ensure the compatibility of materials that are touching, especially those that are designed to stick to each other.

2.2.2 Water Vapor Control

Vapor can be transferred into and out of building materials and assemblies in several ways:

- *Diffusion* of individual molecules of vapor through a solid material, such as unpainted drywall or wood. *Vapor drive* is the force driving diffusion, involving factors such as temperature, humidity level, and air pressure on either side of the material, with the drive moving from higher concentrations to lower. Diffusion can happen without any air transfer through the material.
- Air leakage, during which significant amounts of water vapor can be carried into an assembly by moisture-laden air. This is the largest source of vapor entry into most assemblies in cold climates.
- The evaporation of liquid in an assembly; this is the mechanism of *drying* that allows liquid in saturated materials to leave an assembly.

Water vapor can easily transfer into an assembly through air leakage or diffusion where it can condense on cold surfaces such as sheathing, creating the potential for significant moisture damage. Accordingly, the air and vapor control layers are very important to protect building assemblies from this moisture risk.

2.2.2.1 Relative Humidity and Dewpoint

There are a few ways to measure the amount of moisture in the air. The one most relevant to managing moisture risk in buildings is *relative humidity (RH)*. This is the percentage of water vapor in a volume of air at a given temperature relative to the total amount of water vapor the air can hold. As an example, if the relative humidity is 50%, the air contains half its capacity of water vapor. At 100% relative humidity, the air cannot hold more vapor, and the vapor molecules condense into liquid in the form of condensation on cold surfaces or clouds.

As the air gets warmer, it can hold more water vapor, and the RH% is lower as the amount of vapor in the air is a smaller portion of the increased capacity (assuming no additional water is added to the system). As the air cools, it cannot hold as much vapor, and accordingly the RH% is higher. As the air temperature changes, its capacity to hold vapor changes, and so does the RH%, without the introduction or removal of vapor.

³ Specific flashing instructions are provided in IRC R703.4 Flashing (https://codes.iccsafe.org/content/IRC2018/chapter-7-wall-covering#IRC2018_Pt03_Ch07_SecR703.4)

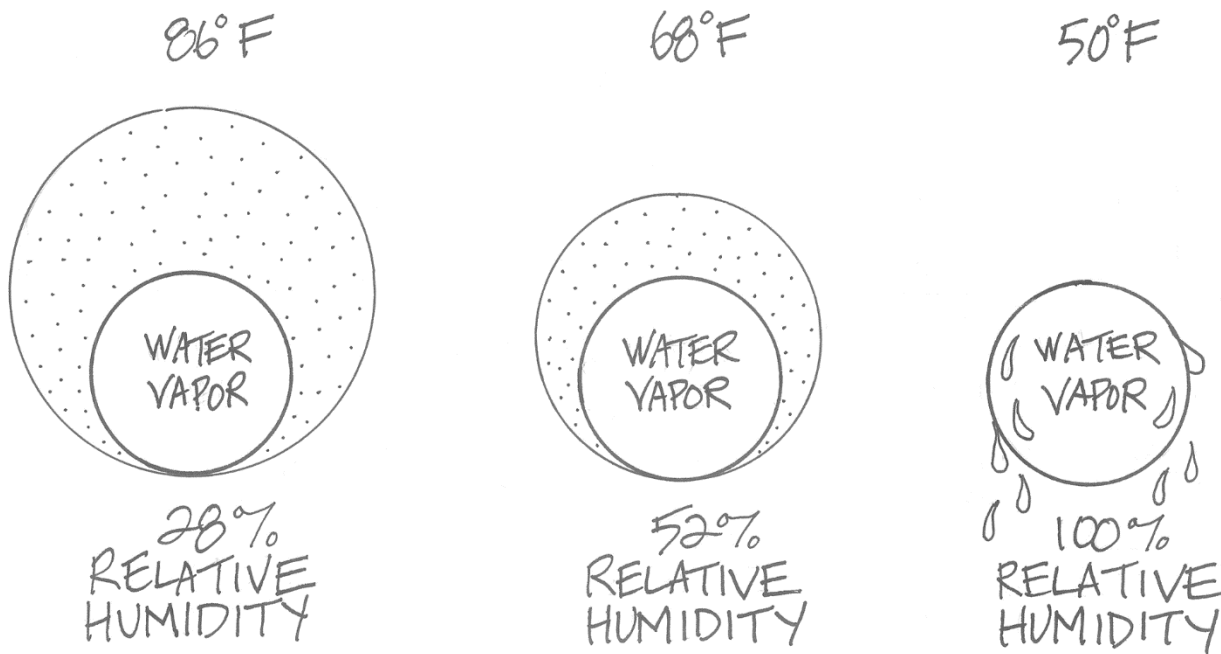


Figure 2.1 – Relative humidity changes as a function of temperature. Illustration credit: Dale Brownson, used by permission from New Society Publishers from the book *Essential Building Science*.

When the temperature of the air drops to the point that the RH reaches 100%, condensation can occur. This temperature is called the *dew point*. When surface temperatures of an object are below the dew point, the air adjacent to those surfaces can cool below the dew point, allowing condensation to form on the surface. A glass of ice water on a hot, humid day is a classic example of this: as the hot humid air is cooled by the surface of the glass, the air temperature drops, and vapor in the air condenses into liquid droplets on the glass.

This can occur inside building assemblies as well. The classic example of this in cold climates is when the wall or roof sheathing outboard of the insulation cools below the dew point of the air in the assembly. At that point, water vapor in the assembly introduced through air leakage or diffusion condenses into liquid on the sheathing (see Figure 2.2). This can also happen on the assembly-side of an interior vapor barrier in a home with the air conditioner running during a hot, humid summer day – the same dynamics as in the winter example, but in reverse.

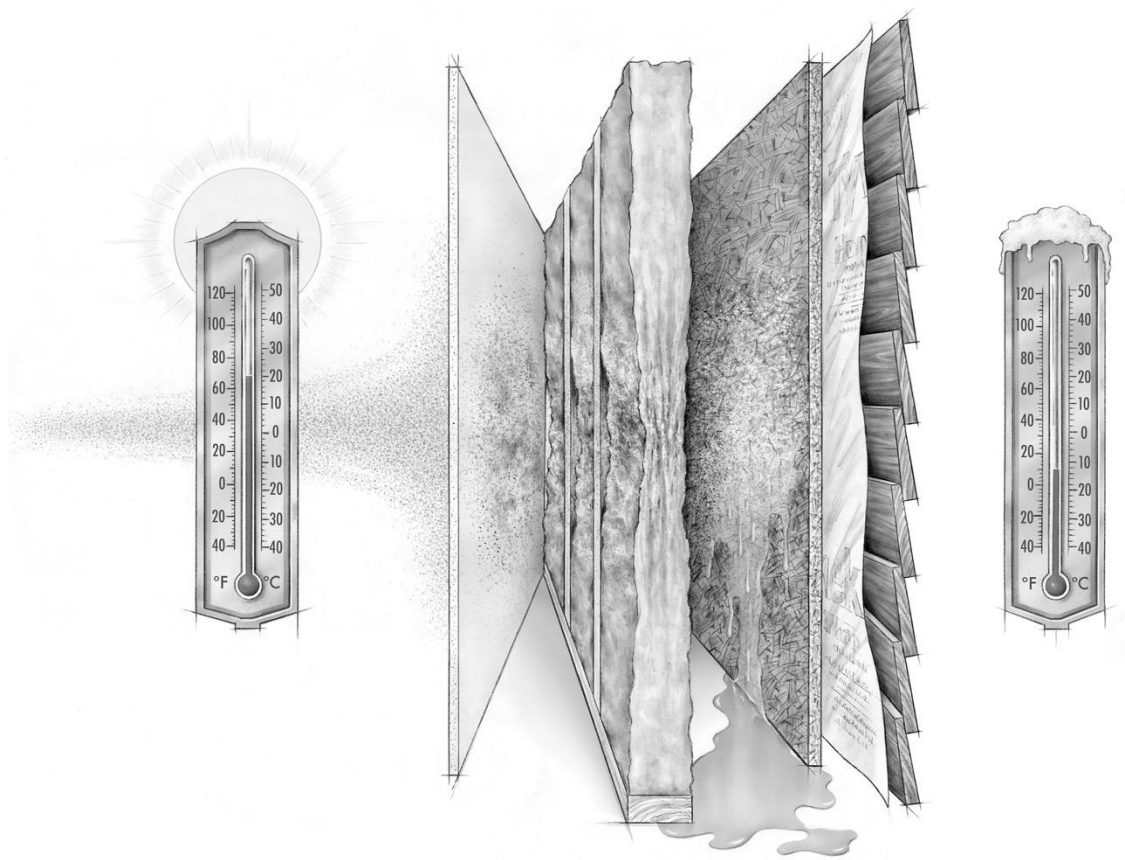
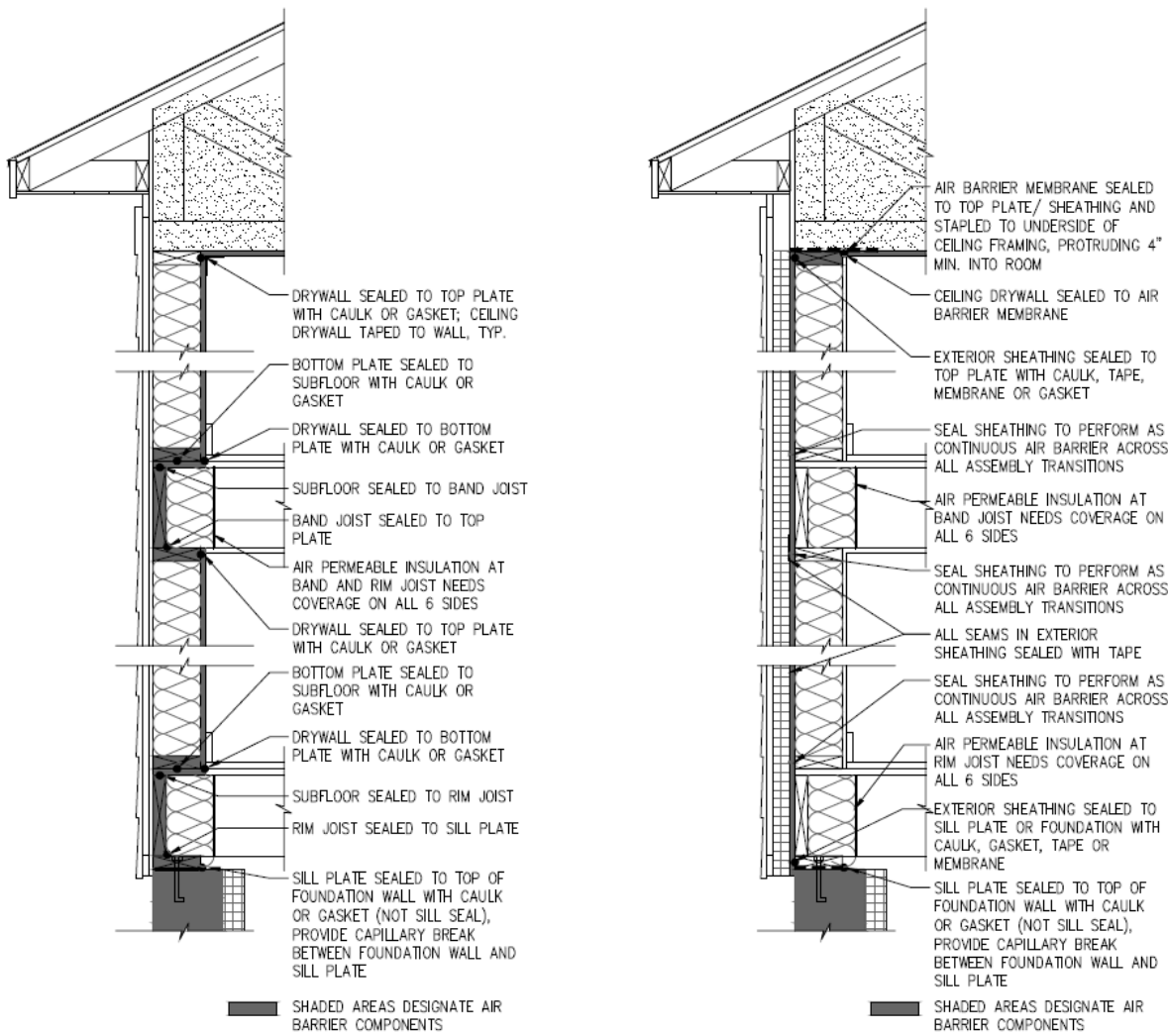


Figure 2.2 – Condensation forming on the inside face of sheathing in a cavity-only insulated wall. Illustration used with permission from Fine Homebuilding.

Understanding the relationship between temperature and relative humidity, and the change from vapor to liquid, is key to understanding the moisture risks that building assemblies face and to developing the strategies to manage these risks.

2.2.2.2 Air and Vapor

A common mistake is to confuse air and vapor, and therefore to confuse the functions and features of air barriers and vapor control layers. Air contains water vapor, and air leakage can move large amounts of this vapor into an assembly. This is why air barriers are so important for moisture control. Air barriers are exactly that – barriers. There are no “levels” of air barrier; the barrier is either intact, or there is a leak. While it is easy to install an air barrier material, connecting the air barrier continuously across all the transitions in the building assemblies can be challenging, especially if not considered in advance of construction. These transitions are explored in Figure 2.3.



A.

B.

Figure 2.3 – Examples of whole-building air sealing via (A) interior-side air barrier and (B) exterior-side air barrier

Water vapor is gaseous water suspended in the air. Water vapor can diffuse through solid materials into or out of an assembly. The permeance of the material determines the amount of vapor diffusion across an assembly for a given vapor pressure. There is a wide range of permeance for different materials. Some materials can even change their permeance based on their moisture content or the ambient relative humidity. While air barriers eliminate air flow, vapor control layers (or “vapor retarders”)⁴ slow but do not necessarily stop all vapor transfer. Different types of vapor control layers are classified based on their permeance, measured in perms (1 perm = 1 grain of water vapor per hour per square foot per inch mercury pressure), as shown in Table 2.2, with material examples shown in Table 2.3.

Table 2.2: Vapor Retarder Permeance Classifications

| Vapor Retarder Class | Description | Permeance |
|----------------------|-----------------------------------|---------------|
| Class I | Vapor impermeable (vapor barrier) | ≤ 0.1 perm |
| Class II | Vapor semi-impermeable | 0.1 to 1 perm |
| Class III | Vapor semi-permeable | 1 to 10 perm |

⁴ See Chapter 3 Section 3.4 for more information on vapor retarders.

Materials greater than 10 perm are considered vapor permeable.

Table 2.3: Common Building Materials and Their Permeance and Vapor Retarder Classifications

| Building Material | Permeance | Vapor Retarder Classification |
|--|---------------------------------------|-------------------------------|
| Vinyl siding, brick veneer | 40 perms due to air leakage | Vapor permeable |
| Wood siding | 10 perms due to air leakage | Vapor permeable |
| #15 asphalt-saturated felt | 5 to 30 perms based on RH% | Vapor permeable |
| Open-cell spray polyurethane foam insulation, 2" | 15 perms | Vapor permeable |
| Housewraps (WRBs) | 5 to 50 perms based on product | Class III |
| Plywood sheathing | 1 to 20 perms based on RH% | Class III |
| OSB sheathing | 1 to 7 perms based on RH% and product | Class III |
| EPS, unfaced, <3" thick | 2 to 4 perms based on product | Class III |
| Typical latex paint and primer | 3 to 10 perms based on product | Class III |
| Vapor-variable membrane | 0.13 to 13+ perms based on RH% | Class II |
| Kraft paper-faced insulation | 0.3 to 3 perms based on RH% | Class II |
| Closed-cell spray polyurethane foam insulation, 2.5" | 0.8 perms | Class II |
| XPS, unfaced, >1" thick | 0.8 perms | Class II |
| Typical oil-based paint, 3 coats | 0.3 to 1 perms based on product | Class II |
| Foil- or polypropylene-faced insulation | <= 0.1 perms | Class I |
| Polyethylene sheet, 6 mil | <= 0.1 perms | Class I |

Managing the diffusion of vapor into and out of building assemblies is important but can be complicated. It is important to stop vapor from diffusing into the assembly, but vapor in the assembly needs to dry out as well. In Vermont’s climate, the vapor drive is usually from the warm, humid indoors toward the colder, drier outdoors. However, in summer when it is warmer and more humid outdoors than indoors, the vapor drive may reverse. This can change over the course of a day, but for homes using air conditioning, the indoor temperature and humidity levels will be lower than the outdoor conditions for most of the summer, and there will be a more consistent vapor drive toward the indoors. Assemblies need to accommodate these changing dynamics over the course of the year.

2.2.2.3 Vapor Variability

Wood-based materials like board sheathing and plywood have variable permeance. When plywood is dry, it is a Class II vapor retarder, but becomes a Class III vapor retarder as the surrounding relative humidity increases. There are *vapor variable membranes* that are designed to behave similarly. These membranes may be Class II under dry (typically winter) conditions, and Class III under more humid (typically summer) conditions. These barriers are typically on the interior in cold climates; they can slow down the outward vapor diffusion that may occur in winter, reducing the risk of condensation in a building assembly, yet allow the house to dry to the inside under higher humidity summer conditions when the vapor drive is toward the indoors, especially if air conditioning is in use. Many of these membranes are also designed to be air barriers, allowing one membrane to serve as multiple control layers, provided it is installed to achieve the function of both an air barrier and vapor retarder.

These membranes are frequently marketed as “smart” membranes, however there is nothing intelligent about them. If they are used in an environment where the indoor relative humidity in the winter is allowed to rise above 70% (e.g. an indoor hot tub room or building with poor humidity management), they will become more permeable and allow the vapor to diffuse into the wall, increasing condensation risk. This illustrates two important principles: 1) the permeance properties of the materials must be well understood to ensure they are appropriate for their application, and 2) assembly design must be put into a holistic context of the indoor and outdoor environments, mechanical design, and occupant behavior to successfully manage risk.

2.2.2.4 Vapor Management Strategies

There are many different strategies to managing vapor in assemblies. To simplify the options, three typical approaches for managing moisture in assemblies in cold climates are:

1. Vapor open, or “flow-through”, assemblies: both sides of the assembly are built with vapor permeable materials, and vapor can dry out of (and diffuse into) both sides of the assembly as the vapor drive changes.

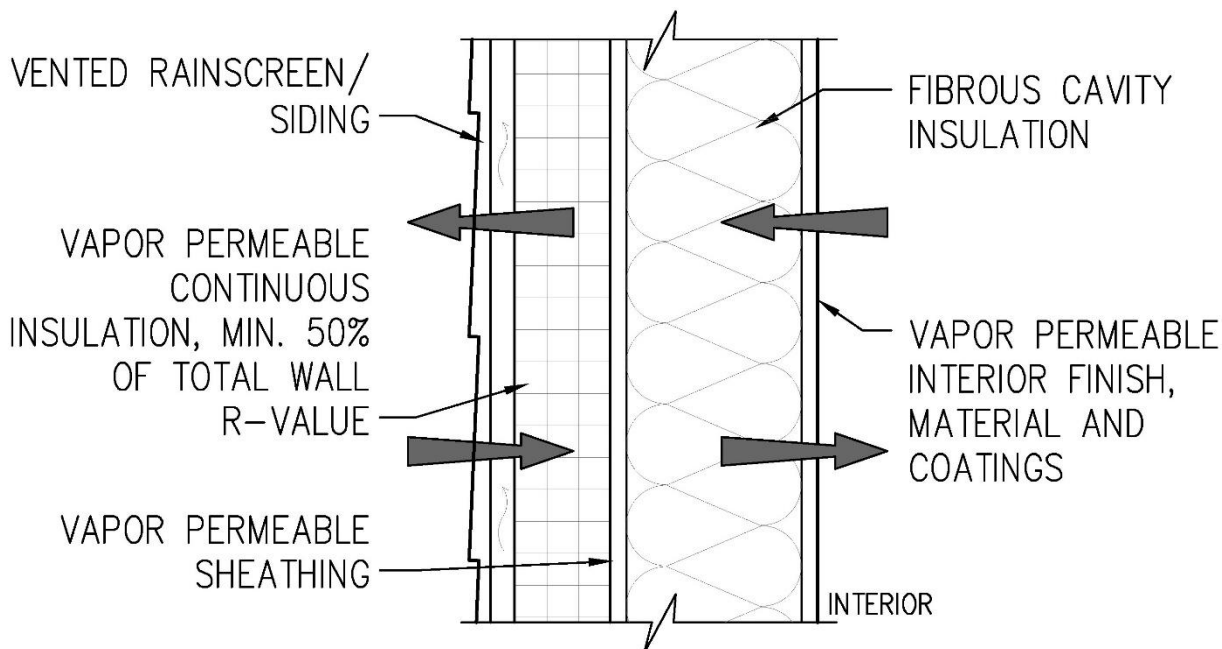


Figure 2.4 – Vapor open assembly

2. Vapor controlled assemblies: the interior of the assembly has a vapor control layer, reducing indoor vapor entering the assembly and allowing drying to the outside.

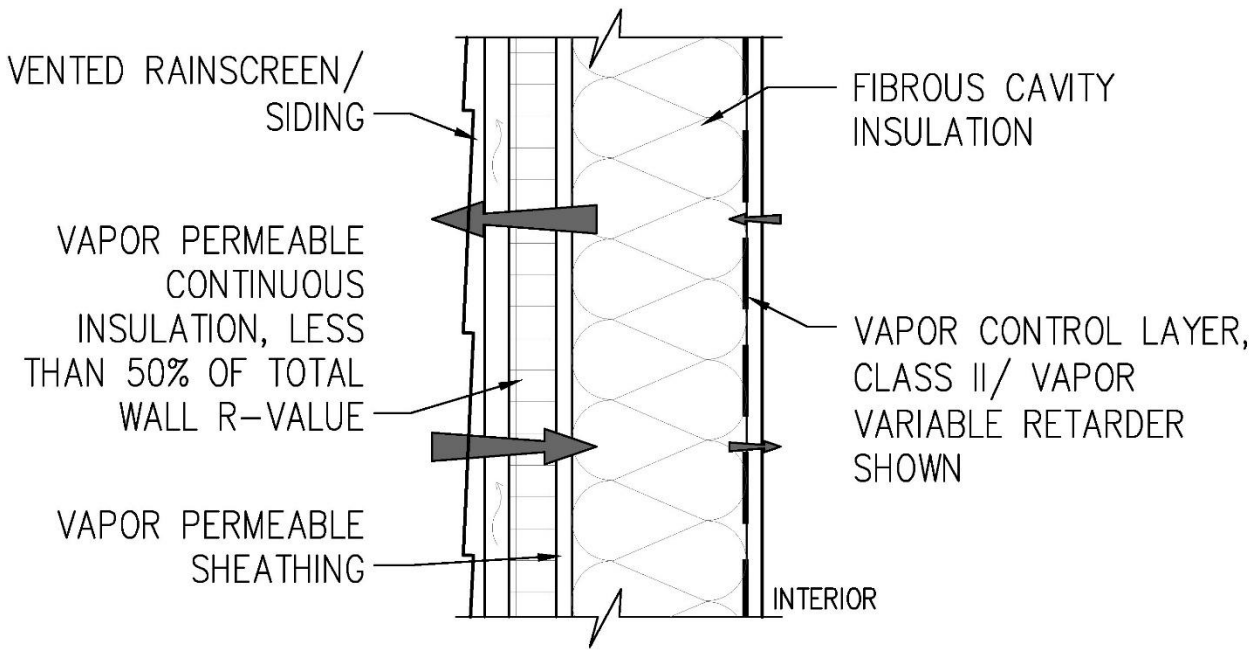


Figure 2.5 – Vapor controlled assembly

3. Wrapped assemblies: enough exterior continuous insulation is provided to keep the sheathing or framing above the dewpoint. Drying may only be to the inside or could be to the outside if permeable insulation is used. The primary strategy is avoiding condensation by keeping the sheathing warm.

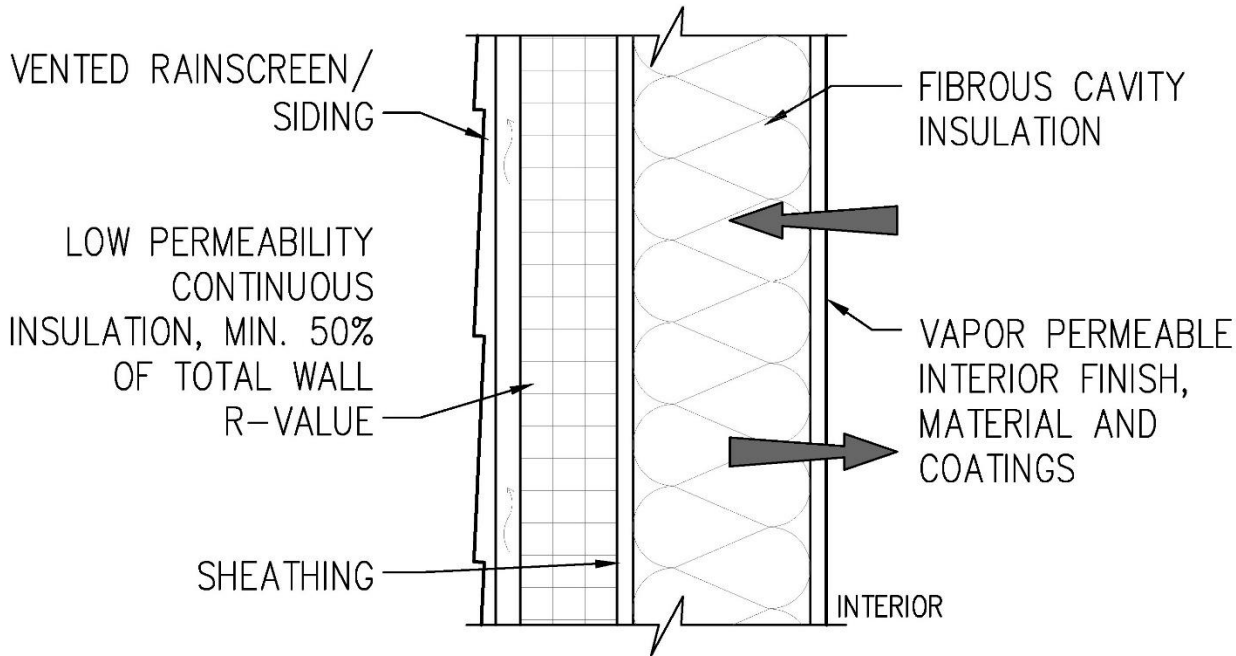


Figure 2.6 – Wrapped assembly

Regarding the wrapped assemblies, code language that restricts a Class I vapor retarder (e.g. 6 mil polyethylene) on the inside of a frame with low permeability insulating sheathing (e.g. foil-faced foam) on the outside is intended to avoid building a wall that can trap moisture inside (“vapor barrier sandwich”) with no drying potential in either direction. An interior Class II vapor retarder would be allowed in this case, given its enhanced ability to allow drying to the inside. A vapor variable membrane would serve this purpose as well.⁵

Vapor open assemblies can be very effective, but they generally require the use of moisture-tolerant materials where dew point may be reached, as periods of condensation may occur throughout the year. Vapor variable membranes are particularly well-suited to vapor controlled assemblies, as they can reduce the diffusion of vapor outward during the winter while allowing an inward drying pathway during the summer.



HIGH RISK OF MOISTURE DAMAGE

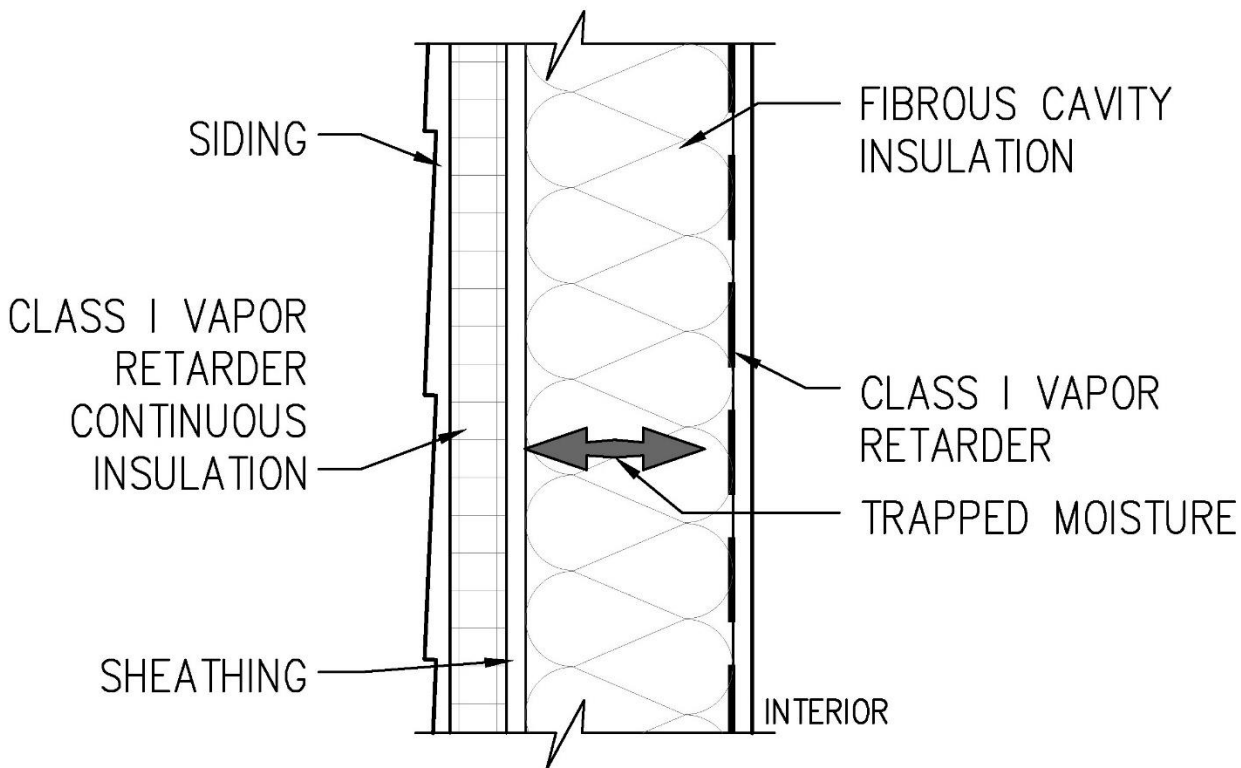


Figure 2.7 – Vapor barrier sandwich

⁵ The IRC provides guidance on the use of different vapor retarders in section R702.7 Vapor retarders (https://codes.iccsafe.org/content/IRC2018/chapter-7-wall-covering#IRC2018_Pt03_Ch07_SecR702.7).

2.2.3 Managing Moisture in Assemblies

As noted in the Introduction, this chapter was included in the Handbook to address moisture risk management associated with the thermal enclosure requirements of the energy code. There are moisture risks associated with increases in thermal performance that must be understood to safely deliver code-compliant building assemblies.

The primary moisture risk associated with increasing insulation levels in building assemblies is the potential for condensation in those assemblies. To explore this risk, two different wall assembly examples are evaluated below: a thick cavity with fibrous insulation (e.g., double stud or thermally broken stud), and a single stud cavity with exterior continuous board insulation. Note that these same principles apply to similar roof assemblies as well.

2.2.3.1 Thick Cavity Risk Management

The thick cavity wall provides more space for insulation and therefore offers improved thermal performance. However, the effect of the insulation slowing heat loss through the assembly means that the sheathing outside of the insulation will be colder than in the single stud assembly. This means the sheathing will be below the dew point for more hours of the year, increasing the risk for condensation on the inner face of the sheathing. There are two ways to manage this risk:

1. Reduce the amount of vapor in the assembly.
2. Ensure sufficient drying of the assembly when condensation does occur.

By far, the biggest source of vapor in an assembly is through air leakage. Air leakage not only contributes to heat loss, but also moisture risk from the water vapor carried in the air into an assembly. Quality air barrier detailing, as well as vapor control layer detailing, is critical to create durable thick cavity assemblies.

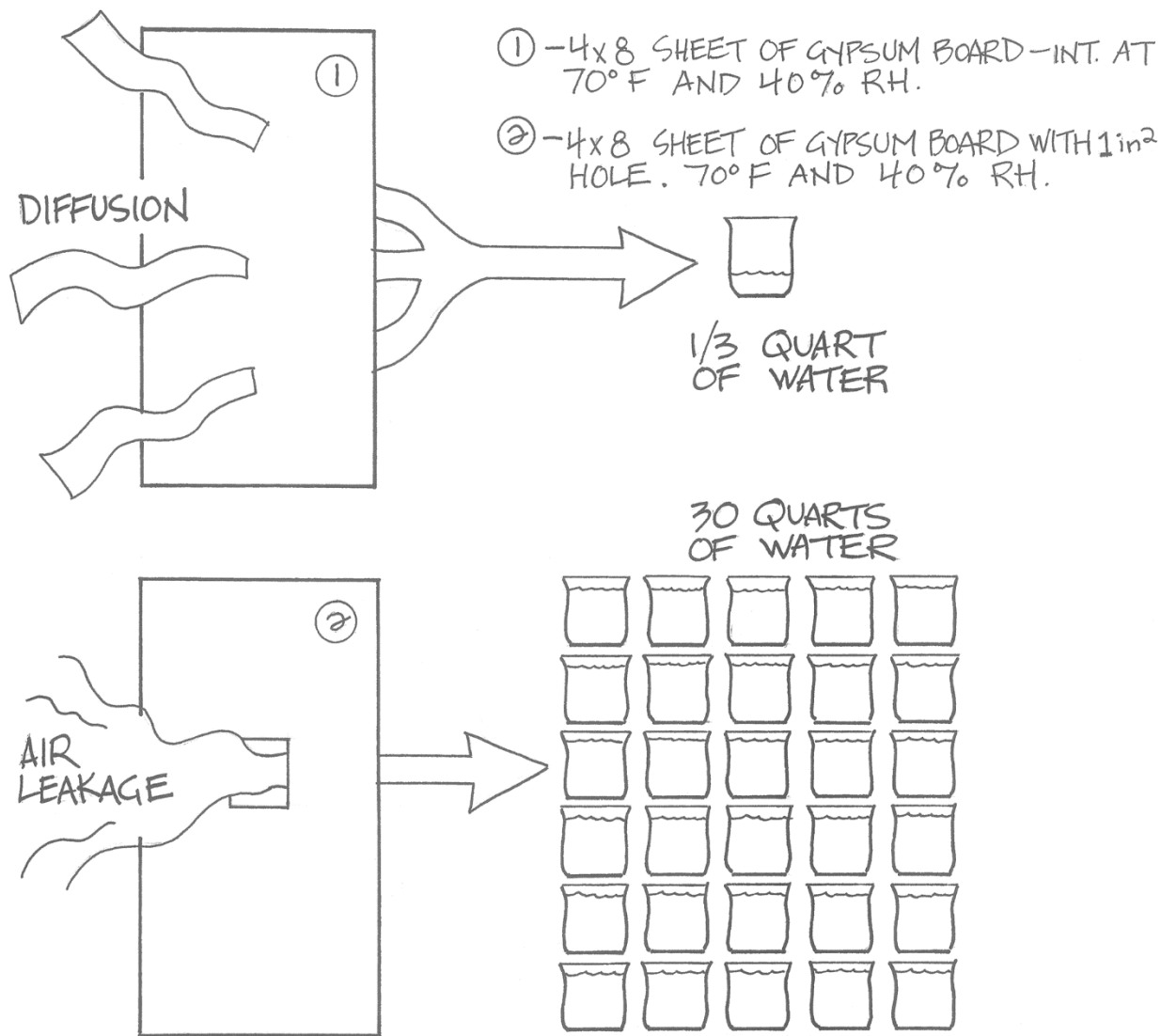


Figure 2.8 – There is roughly two orders of magnitude greater transfer of vapor into a wall from the air leakage through a 1" square hole in a 4'x8' sheet of gypsum wall board than through diffusion through the entire sheet of drywall over the course of a typical winter in Boston, MA, based on research conducted by Building Science Corporation. Illustration credit: Dale Brownson, used by permission from New Society Publishers from the book *Essential Building Science*.

Another source of vapor in an assembly is from diffusion through building materials. In cold climates, this is most frequently diffusion from the inside towards the outside of the building. However, this vapor drive can come from the outside as well during hot, humid summers, especially when the building is air conditioned. Vapor control layers are important to reduce vapor diffusion into the assembly but must be designed carefully to not impede drying when the vapor drive reverses over the course of the year. As evidenced in Figure 2.8, air leakage is by far the largest source of vapor transfer into an assembly, however a well-detailed vapor control layer is also important to protect the assembly.

To facilitate drying the moisture that may condense on the sheathing, there must be a pathway for that moisture to leave the assembly. In the winter, given the location of the condensation near the outside of the assembly and the vapor drive from the warm interior towards the cold exterior, this drying pathway is to the outside. So, the permeance of the sheathing, weather resistant barrier (WRB) or house wrap, and any other layers of the assembly must be high to allow the

condensate to evaporate and diffuse through the assembly to the outside.

It is important to check the permeance of these materials when designing or building a thick cavity assembly to ensure that a low-permeance material is not inadvertently designed into the assembly, leading to reduced drying potential and condensation damage. A vented rainscreen, in which a cavity space is created behind the exterior cladding with atmospheric vents at the top and bottom, can further support the drying potential of the assembly while also reducing the wetting potential from rain events.

2.2.3.2 Single Stud with Exterior Continuous Insulation Risk Management

In this scenario, rather than all the insulation being located inboard of the sheathing, the insulation is split between the cavity inboard of the sheathing and the continuous board insulation outboard of the sheathing. This means that in the winter, the sheathing stays warmer than either the thick wall assembly above or a single stud assembly without exterior insulation. Since the sheathing is warmer, it is below the dew point for fewer hours of the year, and the condensation risk is reduced.

That said, the dew point is a factor of both temperature and humidity. While keeping the sheathing temperature warm will reduce the risk, air barriers are still critical to ensure there is not a build-up of vapor in the assembly. Further, since the exterior continuous insulation is often of a low-permeance material such as foam, vapor in the assembly cannot dry to the outside. Therefore, two things are needed to keep moisture risk low:

1. The board insulation must be thick enough relative to the cavity insulation to keep the sheathing above the dew point
2. There must be a drying pathway to the interior, meaning no Class I Vapor Retarders should be used inboard of the cavity⁶.

Conservatively, 50% of the total R-value of the assembly (cavity plus exterior continuous insulation) should be in the exterior continuous insulation to keep the sheathing above the dew point. If a vapor-permeable board insulation product is used, such as mineral wool or wood fiberboard, this reduces the risk as there is now a drying pathway to the outside, provided the sheathing, WRB, and any other layers outboard of the cavity are also vapor permeable.

2.2.3.3 Moisture Balance

The two scenarios above highlight the importance of considering a balanced approach to managing moisture risk in building assemblies. When we use the combined strategies of reducing the amount of moisture in the assembly and increasing the assembly's drying potential and build with materials that can safely store moisture until sufficient drying can occur, we achieve a moisture balance that allows for durable and resilient assemblies.

⁶ The International Residential Code (IRC) permits Class III vapor retarders inside 2x4 walls with exterior continuous insulation (ci) R-values over 7.5, and inside 2x6 walls with exterior ci R-values over 11.25 (IRC 2018 Table R702.7.1: https://codes.iccsafe.org/content/IRC2018/chapter-7-wall-covering#IRC2018_Pt03_Ch07_SecR702.7.1).

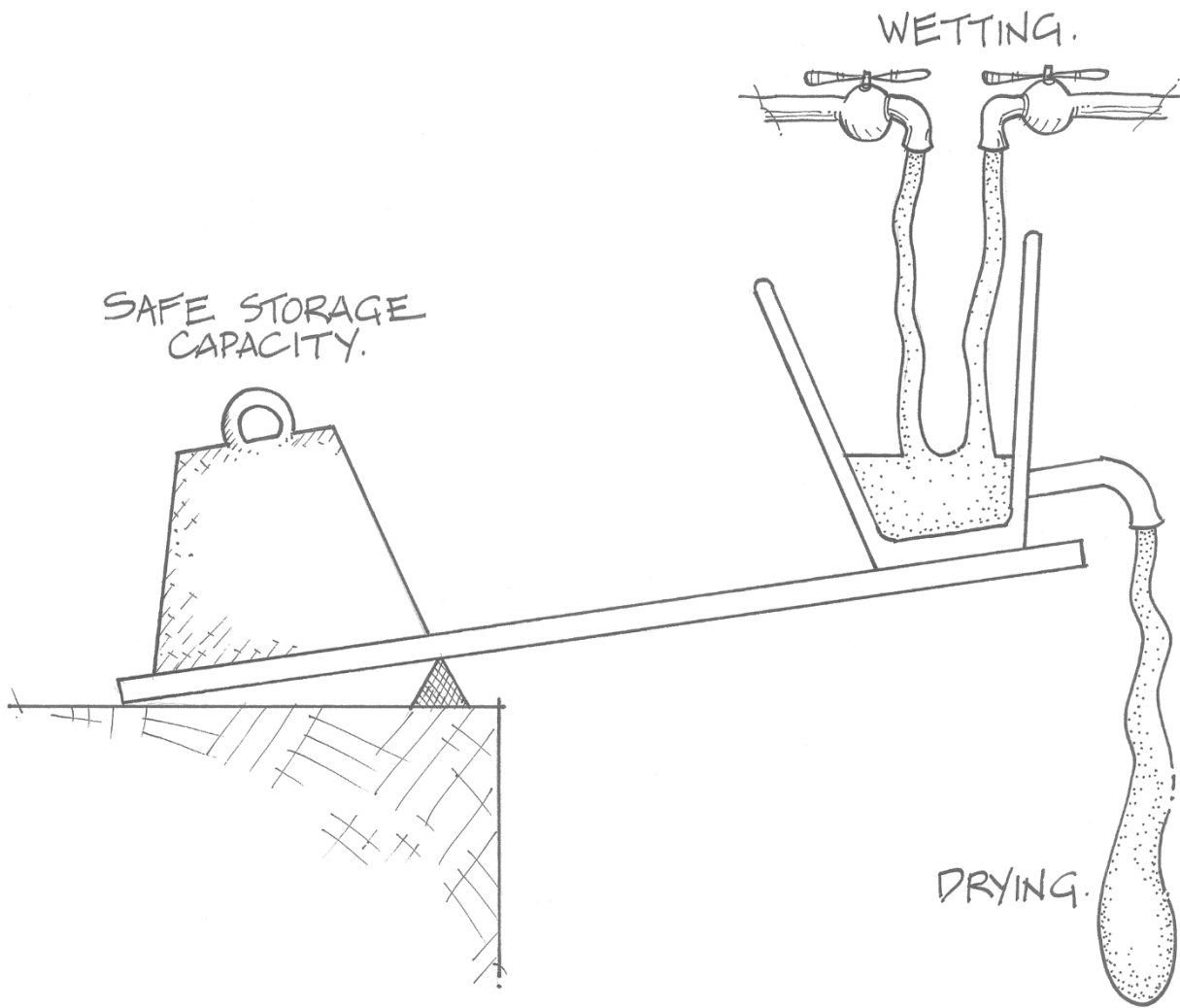


Figure 2.9 – The Moisture Balance Strategy for an assembly requires 1) reducing the amount of water entry through the building control layers, 2) allowing vapor to dry out of the assembly, and 3) using materials that can safely store water until drying conditions are available. Illustration credit: Dale Brownson, used by permission from New Society Publishers from the book *Essential Building Science*.

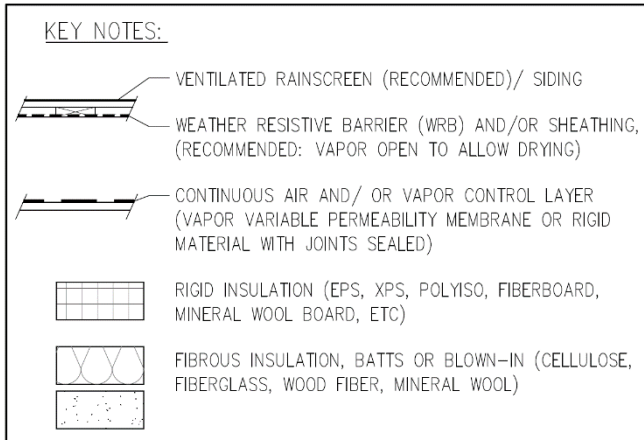
The thick wall scenario demonstrates the importance of this moisture balance: an air barrier is critical to reduce the potential wetting of the assembly, drying potential needs to be provided by using vapor permeable materials outboard of the framing, and the sheathing needs to be able to accommodate some wetting without being damaged. Wood board sheathing and plywood are both materials that can accommodate a moderate amount of wetting for a moderate length of time without sustaining damage and are increasingly vapor permeable as they approach saturation. If a commodity-type OSB sheathing product were to be used, the lower permeance of the OSB and increased risk of damage to the OSB when wetted would tip the moisture balance to a riskier building assembly. By keeping the moisture balance in mind when designing and building assemblies, high levels of insulation can be achieved while still successfully managing the moisture risk in our buildings.

2.3 Assembly Examples

This section explores examples of different building assemblies that can be used to comply with the code, as well

as common challenging areas in buildings. These examples are not intended to be comprehensive, but rather representative of the strategies and approaches that can be used to address the challenges detailed throughout this chapter. Explanations of the moisture risks and risk management strategies demonstrated in these examples can be found in the sections following these examples. More information can be found in *Section 2.4 Resources*.

Please note that these examples are provided for general guidance only. The principles of moisture management should be considered for the specifics of each project.



The legend at left is a reference for the following Figures. Important: A properly detailed rainscreen makes these assemblies safer from a moisture perspective.

2.3.1 Foundation Wall

Below-grade walls are subject to a unidirectional vapor drive and moisture load from the ground inward. Therefore, moisture control strategies are different than for above grade walls, as there is no condition in which the wall is expected to dry to the outside. A Class I or II vapor retarder should not be used on the interior side of fiber insulation in a below-grade assembly⁷.

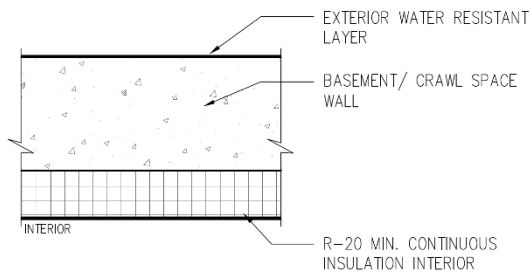


Figure 2.10 – Foundation wall with interior foam continuous insulation

Placing all the insulation to the interior of the foundation wall avoids the expense of protecting exterior insulation and the risk of its degradation due to insects, UV, and abrasion (e.g. landscaping activities). This allow allows for more flexible sequencing by avoiding insulation installation prior to backfilling. However, care must be taken to ensure the insulation is fully sealed to the wall and that all seams are sealed to avoid air leakage resulting in condensation on the concrete wall behind the insulation.

⁷ The IRC provides an exemption for the use of Class I or II vapor retarders for basement walls and below-grade portions of walls in Table R702.7.1 Class III vapor retarders (https://codes.iccsafe.org/content/IRC2018/chapter-7-wall-covering#IRC2018_Pt03_Ch07_SecR702.7.1).

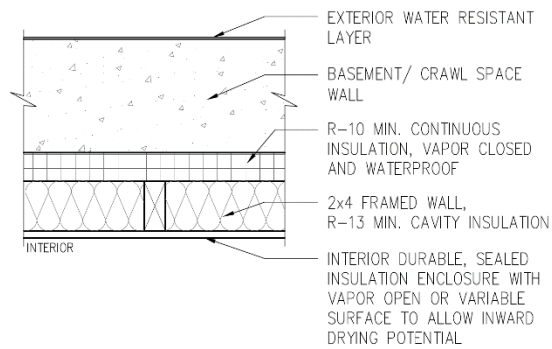


Figure 2.11 – Foundation wall with interior fiber cavity and foam continuous insulation

Placing air-sealed vapor-closed continuous foam insulation against the interior of the foundation wall moves the dewpoint to the inside face of the foam. This creates a moisture-durable condition to allow framing and fibrous cavity insulation to be placed inboard of the foam insulation. Approximately 50% of the total R-value should be provided by the continuous insulation to ensure the interior face stays above the dewpoint. The materials inboard of the frame wall should be vapor open or vapor variable to allow inward drying potential.

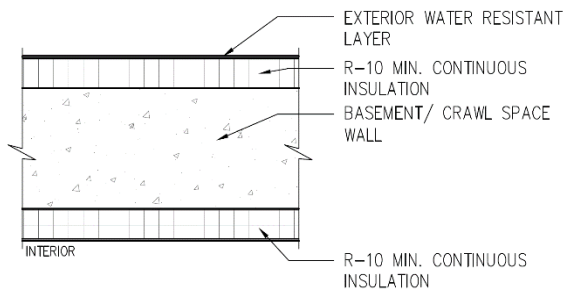


Figure 2.12 – Foundation wall with interior and exterior foam insulation (insulated concrete form, or ICF)

The use of insulated concrete forms (ICFs) allows for the efficient construction of well-insulated concrete walls as the insulation is incorporated into the formwork without additional steps. Exterior insulation must be well-protected from insects, UV, and abrasion (e.g. landscaping activities). The manufacturer’s installation and finishing instructions must be carefully followed to ensure durability and moisture management of their proprietary system.

2.3.2 Slab Edge

Heat loss at the slab edge for slabs on grade and walk-out basement slabs is challenging to manage. Excessive heat loss at these locations can create moisture problems due to condensation on cold concrete surfaces, or even liquid moisture transfer into the slab from the outside. In this instance, controlling the heat loss through the slab edge with insulation is part of a moisture control strategy.

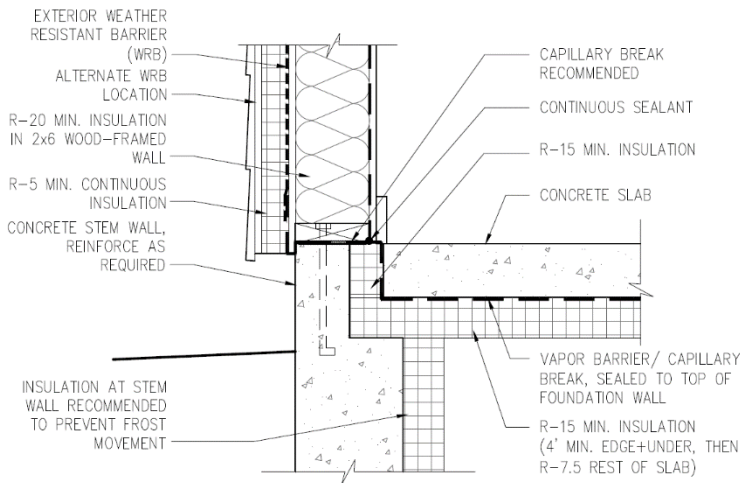


Figure 2.13 - Slab edge insulation with 2x6 above grade wall (R-20+5ci shown)

By placing a thermal break of board insulation between the slab and the foundation wall, thermal control (insulation) is nearly continuous from the wall insulation to the sub-slab insulation and the slab edge can no longer conduct heat directly from the building to the outside. It is important to correctly design the thickness of this insulation to ensure appropriate structural performance of the wall as well as full coverage of the insulation on the interior by the wall, trim, or flooring, while still providing sufficient thermal control.

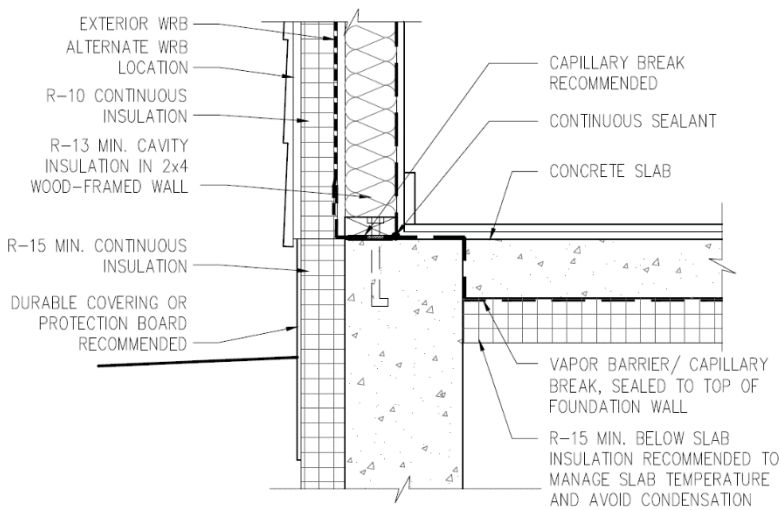


Figure 2.14 – Exterior foundation and sub-slab insulation with 2x4 above grade wall (R-13+10ci shown)

The plane of a thicker layer of continuous insulation on the above grade wall aligns well with the plane of exterior insulation of the foundation wall, and the thermal break between the slab edge and foundation wall can be omitted. Insulation is required beneath the slab to avoid thermal losses to the ground. There will still be thermal loss from the slab edge to the foundation wall, which is in direct contact with the ground. Therefore, while this approach avoids the greater risk thermal bridging to outdoor air temperatures, it is not as good of a thermal control strategy as the slab edge insulation scenario shown in Figure 2.13.

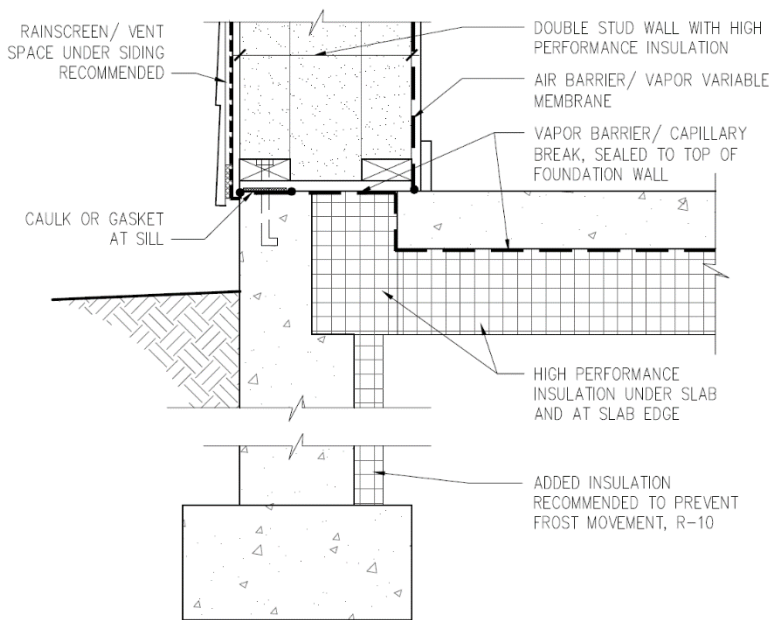


Figure 2.15 – Slab edge insulation with double stud above-grade wall

This high-performance scenario provides the maximum amount of moisture durability by controlling thermal loss with high levels of insulation. The thickened above grade wall allows room for a greater amount of slab edge insulation while allowing sufficient bearing thickness of the concrete wall beneath the outer frame line and full coverage of the insulation by the wall above.

2.3.3 Above-Grade Wall

As described in the sections earlier in this chapter, these are typical examples of above-grade wall assemblies that can be used to comply with the energy code, with notes regarding their moisture risk management. Also included are two higher-risk wall assemblies that are discouraged for use in the Vermont climate.

| | |
|--|--|
| | <h4>EXTERIOR RIGID INSULATION</h4> <ul style="list-style-type: none"> Relies on sufficient outboard continuous insulation to keep the sheathing above the dewpoint in winter; conservative practice suggests targeting minimum 50% of wall's total R-value outside the sheathing. Vapor variable membrane on the inside slows outward vapor migration yet allows drying to the inside; class I vapor barrier on interior can increase this wall's risk of moisture problems. If exterior rigid is vapor open (e.g. fiberboard, mineral wool board), wall can dry outwards depending on properties of exterior layers. |
|--|--|

| | |
|--|---|
| <p>POTENTIAL AIR BARRIER LOCATIONS</p> <p>ALTERNATE WRB LOCATION</p> <p>R-5 VAPOR OPEN INSULATION (E.G. FIBERBOARD, MINERAL WOOL BOARD)</p> <p>VAPOR OPEN SHEATHING</p> <p>2x6 FRAMED WALL, R-20 INSULATION IN CAVITY</p> <p>CLASS 1 OR 2 VAPOR RETARDER, VAPOR VARIABLE MEMBRANE RECOMMENDED</p> <p>U-0.042</p> | <h3>THIN EXTERIOR RIGID INSULATION - VAPOR OPEN</h3> <ul style="list-style-type: none"> • Sheathing spends time below dewpoint in winter, but with proper design, it can dry sufficiently while resisting outward vapor migration in winter. • Class I vapor barrier on interior limits drying to the inside and may increase risk of moisture problems during the summer. |
| <p>POTENTIAL AIR BARRIER LOCATIONS</p> <p>R-5 NAILBASE PANEL (SHEATHING OUTSIDE RIGID INSULATION)</p> <p>2x6 FRAMED WALL, R-20 INSULATION IN CAVITY</p> <p>CLASS 1 OR 2 VAPOR RETARDER, VAPOR VARIABLE MEMBRANE RECOMMENDED</p> <p>U-0.042</p> | <h3>NAILBASE PANEL</h3> <ul style="list-style-type: none"> • Sheathing may spend time below dewpoint in winter, but first condensing surface is the foam; with proper design and attention to detail, condensation risk can be managed. • Vapor variable membrane on the inside slows outward vapor migration yet allows inward drying; Class I vapor barrier on interior limits drying to the inside and may increase risk of moisture problems. • Given limited outward drying potential, a high quality air barrier is required to limit air/ vapor entry into wall assembly. |
| <p>POTENTIAL AIR BARRIER LOCATIONS</p> <p>CUSTOM THERMALLY-BROKEN STUD, (E.G. 2x6 + R-5 RIGID INSULATION AND PLYWOOD)</p> <p>2x8 FRAMED DEPTH, R-26 INSULATION IN CAVITY</p> <p>CLASS 1 OR 2 VAPOR RETARDER, VAPOR VARIABLE MEMBRANE RECOMMENDED</p> <p>U-0.041</p> | <h3>THERMALLY-BROKEN STUD</h3> <ul style="list-style-type: none"> • Sheathing spends time below dewpoint in winter, but this design is essentially a thermally broken 2x8 cavity wall that can dry to the exterior. • Wall may dry to the interior, if vapor variable membrane used rather than Class I vapor barrier. • Increased cavity insulation increases condensation risk of sheathing; high quality air barrier is required to limit air/ vapor entry into wall assembly. |
| <p>POTENTIAL AIR BARRIER LOCATIONS</p> <p>R-40 INSULATION, ENTIRE FRAMED CAVITY FILLED (NO AIR GAPS)</p> <p>CLASS 1 OR 2 VAPOR RETARDER, VAPOR VARIABLE MEMBRANE RECOMMENDED</p> <p>U-0.026</p> | <h3>DOUBLE STUD</h3> <ul style="list-style-type: none"> • Sheathing spends time below dewpoint in winter. • Depending on detailing, wall can dry in one or both directions. • Fibrous insulation may add moisture buffering capability, depending on product. • Class I vapor barrier on interior limits drying to the inside and may increase risk of moisture problems during the summer. • Increased cavity insulation increases condensation risk of sheathing; high quality air barrier is required to limit air/ vapor entry into wall assembly. |

| | |
|--|--|
| <p>POTENTIAL AIR BARRIER LOCATIONS</p> <p>EXTERIOR I-JOIST OR LARSEN TRUSS</p> <p>R-34 INSULATION IN EXTERIOR CAVITY</p> <p>9 1/4"</p> <p>SHEATHING</p> <p>2x4 INNER BEARING WALL, R-13 INSULATION IN INTERIOR CAVITY</p> <p>INTERIOR</p> <p>U-0.023</p> | <h3>TJI LARSEN TRUSS</h3> <ul style="list-style-type: none"> Relies on sufficient outboard continuous insulation to keep the sheathing above the dewpoint in winter; conservative practice suggests targeting min. 50% of wall's total R-value outside the sheathing. Depending on detailing, wall can dry in one or both directions. Class I vapor barrier on interior limits ability of inward drying to the inside and may increase risk of moisture problems during the summer. |
| <p>POTENTIAL AIR BARRIER LOCATIONS</p> <p>SEALANT, SPLINE, INSTALLED PER MANUFACTURER'S INSTRUCTIONS</p> <p>R-20 STRUCTURAL INSULATED PANEL (SIP)</p> <p>INTERIOR</p> <p>U-0.043</p> | <h3>SIP</h3> <ul style="list-style-type: none"> If detailed correctly, resists vapor movement into assembly and there are no internal condensing surfaces. Panel joints must be detailed correctly as a continuous air barrier to avoid failure; note that framing may move over time, breaking essential seals, so taped seams (both interior and exterior) in addition to sealed joints recommended. |
| <p>POTENTIAL AIR BARRIER LOCATIONS</p> <p>2x6 FRAMED WALL, R-20 INSULATION IN CAVITY</p> <p>CLASS 1 OR 2 VAPOR RETARDER, VAPOR VARIABLE MEMBRANE RECOMMENDED</p> <p>INTERIOR</p> <p>U-0.058</p> | <h3>CAVITY ONLY</h3> <ul style="list-style-type: none"> Sheathing spends time below dewpoint in winter, but with proper design, it can dry sufficiently while resisting outward vapor migration in winter. Class I vapor barrier on interior limits drying to the inside and may increase risk of moisture problems during the summer. Advanced framing techniques are recommended to reduce thermal bridging. |

Figure 2.16 – Wall assemblies that can work in Vermont with well-managed moisture risk.

Table 2.4: Comparing Different Wall Assemblies

| Wall Type | Pros | Cons | Notes |
|---|--|--|---|
| Exterior Rigid Insulation | <ul style="list-style-type: none"> Thick exterior insulation improves thermal performance and protects sheathing from condensation Framing details are typical | <ul style="list-style-type: none"> Exterior trim and flashing details can be complicated and expensive No exterior drying potential with vapor-closed rigid insulation | Vapor permeable insulation can allow for outward drying potential |
| Thin Exterior Rigid Insulation – Vapor Open | <ul style="list-style-type: none"> Vapor open rigid insulation allows outward drying potential Framing and exterior details are typical | <ul style="list-style-type: none"> Minimal rigid insulation thickness increases condensation risk Lower thermal performance | Must use vapor permeable rigid insulation |

| | | | |
|-----------------------|---|---|---|
| Nailbase Panel | <ul style="list-style-type: none"> • Combined insulation/sheathing product is easy to install • Framing and exterior details are typical | <ul style="list-style-type: none"> • Minimal rigid insulation thickness increases condensation risk • Lower thermal performance | Air-tight construction is required to reduce condensation risk; vapor-variable interior membrane strongly recommended |
| Thermally-Broken Stud | <ul style="list-style-type: none"> • Thick cavity improves thermal performance • Framing and exterior details are typical | <ul style="list-style-type: none"> • Thick cavity increases condensation risk • Additional detailing to create and finish thicker cavity | Air-tight construction is required to reduce condensation risk; vapor-variable interior membrane strongly recommended |
| Double Stud | <ul style="list-style-type: none"> • Thick cavity improves thermal performance • Framing and exterior details are typical depending on design | <ul style="list-style-type: none"> • Thick cavity increases condensation risk • Additional detailing to create and finish thicker cavity | Air-tight construction is required to reduce condensation risk; vapor-variable interior membrane strongly recommended |
| TJI Larsen Truss | <ul style="list-style-type: none"> • Thick exterior cavity improves thermal performance and protects sheathing from condensation • Good option for exterior retrofits | <ul style="list-style-type: none"> • Thick cavity increases condensation risk for nailbase (if used) • Additional detailing to create and finish thicker cavity | Options for air and vapor control strategies, exterior detailing require careful design |
| SIP | <ul style="list-style-type: none"> • Air-tight continuous insulation improves thermal performance and reduces condensation risk • Panel system can increase construction efficiency | <ul style="list-style-type: none"> • Joints between panels can create condensation risk if not carefully sealed • Proprietary system may limit material options | Air-tight detailing at all panel edges critical for long-term durability and thermal performance. |
| Cavity Only | <ul style="list-style-type: none"> • Thinnest wall option • Framing and exterior details are typical | <ul style="list-style-type: none"> • Minimal insulation increases condensation risk • Lowest thermal performance | Air-tight construction is required to reduce condensation risk; vapor-variable interior membrane strongly recommended |


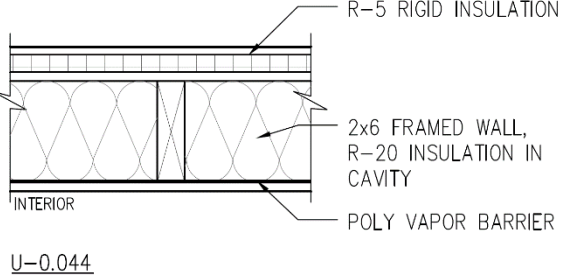

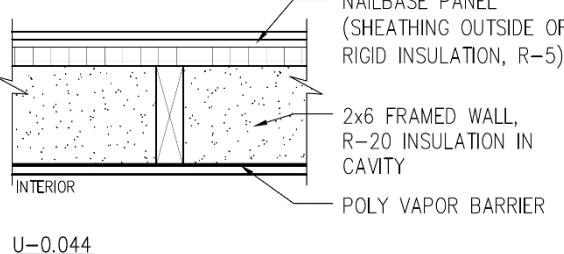
| | |
|---|---|
|   | <p>THIN EXTERIOR RIGID INSULATION WITH INTERIOR VAPOR BARRIER</p> <p>VAPOR CLOSED</p> <ul style="list-style-type: none"> • Insulation isn't thick enough to prevent the sheathing from spending time below the dewpoint in winter, creating risk of condensation. • Class I interior vapor barrier prevents drying inwards and vapor closed rigid insulation prevents drying outward; any moisture in the wall, cannot dry quickly or easily. • Also considered a "vapor barrier sandwich." |
|   | <p>NAILBASE PANEL WITH INTERIOR VAPOR BARRIER</p> <ul style="list-style-type: none"> • Insulation isn't thick enough to prevent the foam sheathing from spending time below the dewpoint in winter, creating risk of condensation. • Class I vapor barrier prevents drying inwards and foam layer prevents drying outward; any moisture in this wall cannot dry quickly or easily. • Also considered a "vapor barrier sandwich." |

Figure 2.17 - Two examples of walls that are higher moisture risk in Vermont.

2.3.4 Above-Grade Problem Areas

Knee walls present unique challenges in defining the air, thermal, and vapor control layers of the enclosure. Most problems arise when the boundary is not clearly defined and fully executed. Two common approaches are shown in the figures below. Overhanging floors and attached porches also provide challenges in continuity of the control layers of the building, and included are examples of good detailing for those areas.

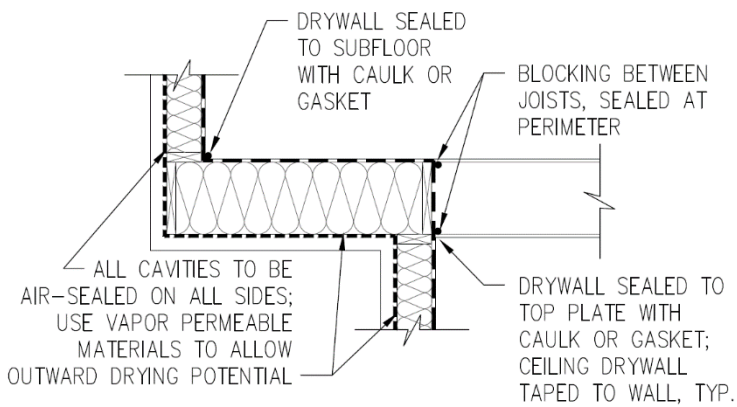


Figure 2.18 - Overhanging (cantilevered) floor

It is important to bring the same level of rigor in enclosure details to overhanging floors as for above-grade walls. For the purposes of moisture management, apply the same principles for walls in this situation: air-tight construction, continuous quality insulation, vapor management and drying potential, and liquid water management.

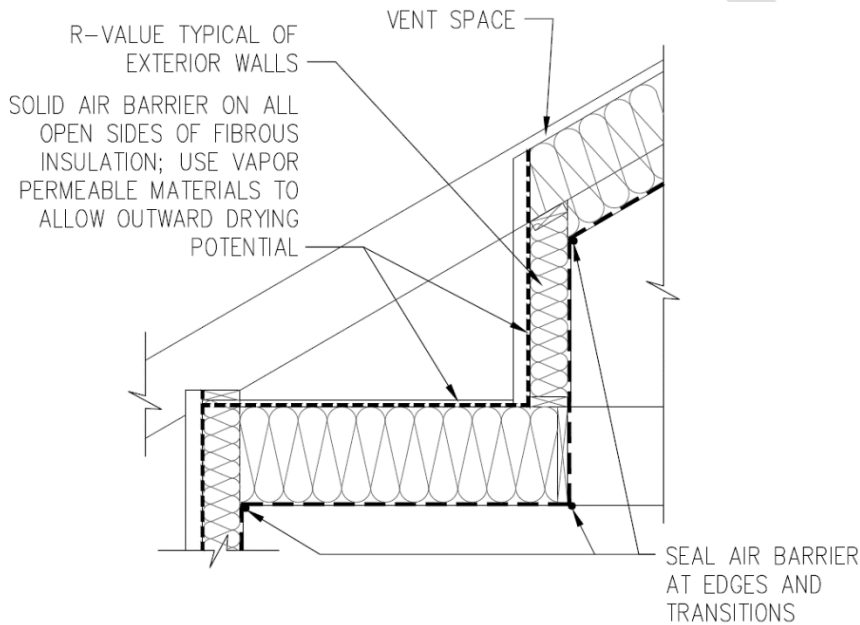


Figure 2.19 – Kneewall condition, outside the building enclosure.

The biggest challenge with kneewalls is identifying what assemblies are part of the building enclosure. The example shown in Figure 2.19, the space behind the kneewall is outside the thermal enclosure and therefore the kneewall as well as the section of floor connecting the kneewall to the perimeter wall below need to be treated as enclosure assemblies, with appropriate air sealing, insulation, and vapor control. Note that the bulk water control for this area is managed by the roof above. This is a more difficult approach with more transitions and is generally not a recommended strategy.

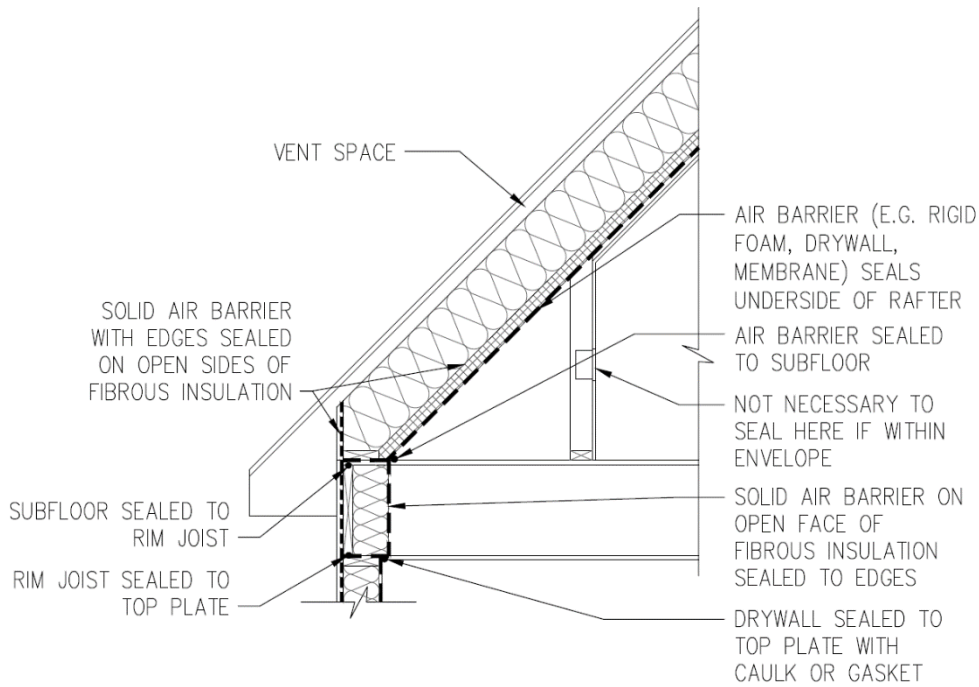


Figure 2.20 – Kneewall conditions, inside the building enclosure.

In the kneewall approach taken in Figure 2.20, the kneewall, the space behind the kneewall, and the floor below that space are all brought into the building enclosure by continuing the insulation and air sealing in the roof through the floor rim joist area to the wall below. This is a simpler approach to creating continuity from the roof to the lower wall with fewer transitions and is the recommended approach for kneewall conditions.

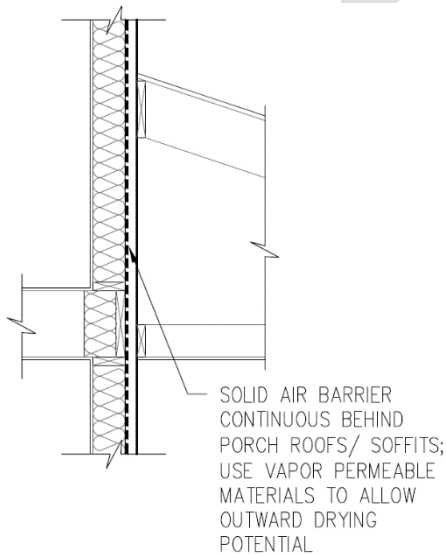


Figure 2.21 – Porch roof detail at enclosure wall

When a porch roof meets an enclosure wall, the air barrier and insulation layers of the wall must be continuous and not interrupted by the porch roof. While the bulk water control layer will need to be flashed to accommodate the porch roof, the air barrier should be designed and installed such that any attachment framing or fastening for the porch roof does not impact the quality of the air barrier or continuous insulation, if present. Further, vapor open materials should be used to facilitate outward drying potential if that is part of the enclosure wall strategy.

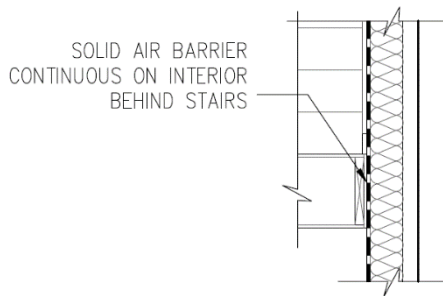


Figure 2.22 - Exterior wall below stair landing

Enclosure walls with connected stairs are another location to detail and construct with care. As per the porch roof condition, it is important to ensure that all air, vapor, and thermal control layers are continuous and not interrupted by stair framing or attachment.

2.3.5 Vented Roof Assemblies

Vented roof assemblies allow for the passage of outdoor air under the roof decking. This provides two main benefits from a moisture standpoint. By keeping the roof decking and roofing cold in winter, the risk of ice damming is reduced, avoiding potential roof leaks and damage. Additionally, a vented roof provides a cavity into which outward drying occur. Like slab edges, the transition from the top of a framed wall to the insulated ceiling can be a place of excessive heat loss and resulting moisture problems. Accordingly, examples of thermally broken assembly strategies are shown below to reduce this risk.

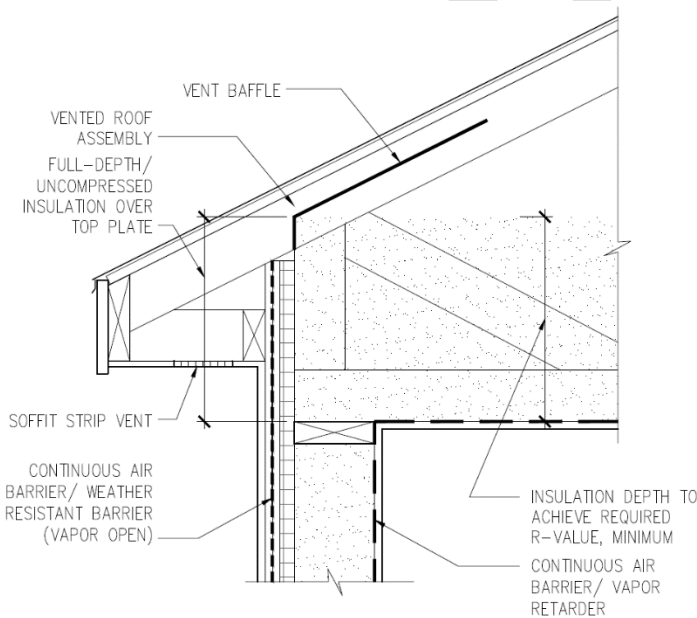


Figure 2.23 - Raised heel truss

When using a truss roof frame, the truss can be designed with a “raised heel” to allow for full installation depth of the roof insulation over the top plate as shown in Figure 2.23. This helps avoid thermal loss at the roof-to-wall junction that

can contribute to ice dam conditions, as well as improve the thermal performance of the building. It is important to air seal the end of the truss from the vent baffle down to the top plate to avoid “wind-washing” of the fibrous insulation beneath the roof vent plane.

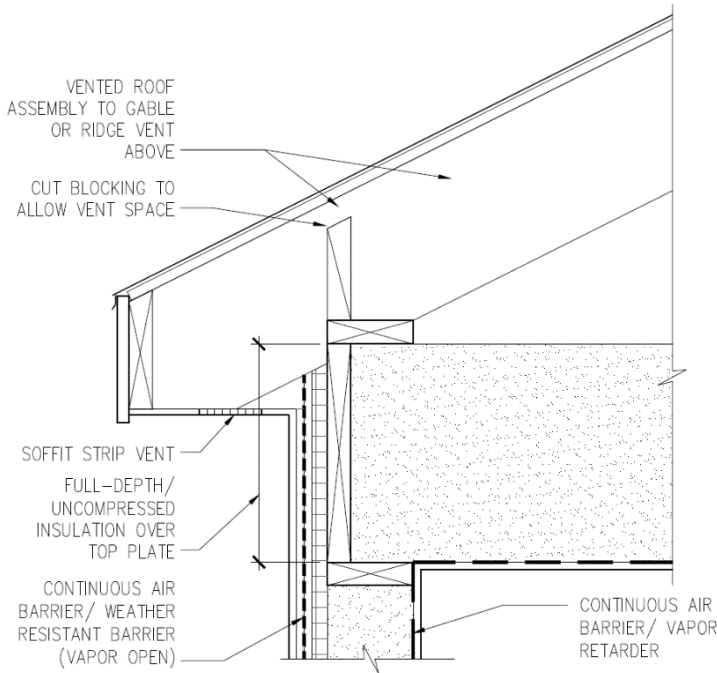


Figure 2.24 - Raised rafter

Like the raised heel truss approach shown in Figure 2.23, the rafter can be raised above the height of the attic floor framing to allow full depth of insulation to be installed above the top plate as shown in Figure 2.24. A ventilation inlet can be framed into the rafter cavity ends to provide venting for the assembly.

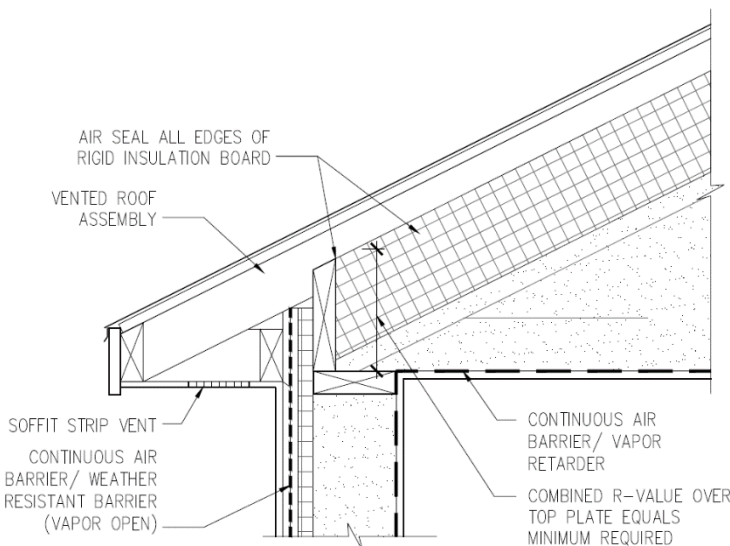


Figure 2.25 - Rigid board insulation above top plate

Rigid board insulation can be used to create the vent plane between rafters, which provides an opportunity to reduce the height of the framing while still providing full assembly R-value above the top plate, given the high R-value per inch of many rigid board insulation products. All edges of the board insulation should be air-sealed. If the board insulation

is vapor-closed, approximately 50% of the combined R-value of the rigid and fibrous insulation should be in the board insulation to avoid condensation on the inside face of the board insulation.

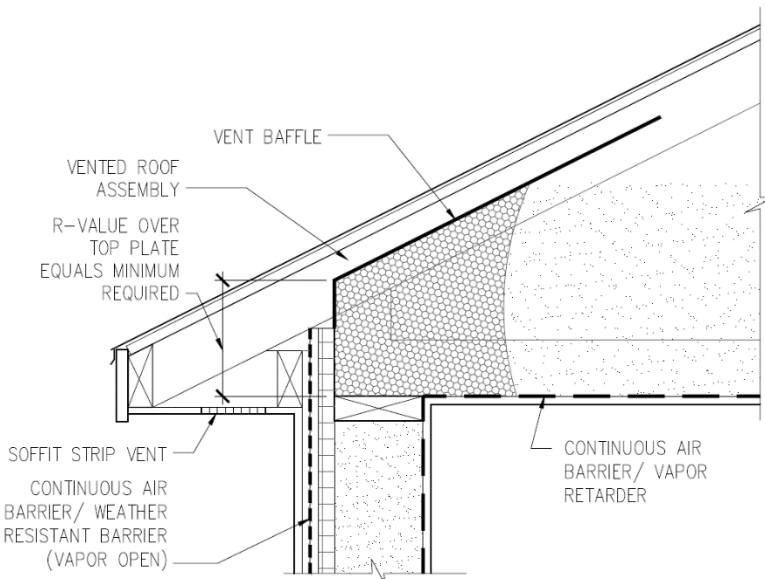


Figure 2.26 – Spray foam above wall plate

Like the rigid board insulation above the top plate shown in Figure 2.25, spray polyurethane foam (SPF) can be used as a higher R-value per inch insulation to reduce the framing height above the top plate as shown in Figure 2.26. SPF also has the value of being able to fill complex areas easily and completely, such as this roof-to-wall transition, as well as providing both air-barrier and insulation services.

2.3.6 Unvented Roof Assemblies

Unvented roofs present an increased moisture risk, both because of ice damming and reduced outward drying potential for the roof assembly. Shown below are examples of unvented roof details designed to maintain thermal performance while managing these moisture risks.

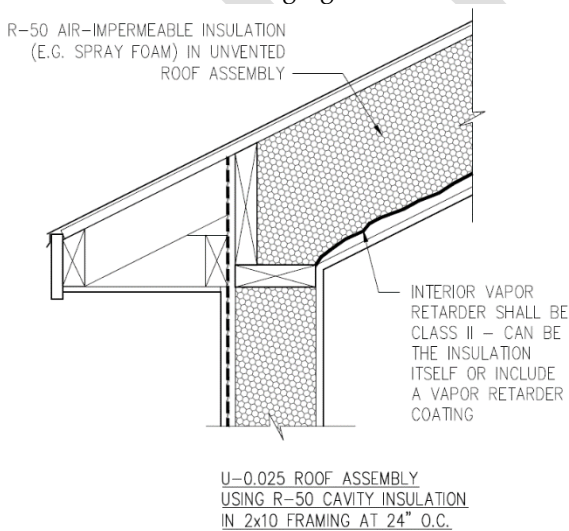


Figure 2.27 – Spray polyurethane foam cavity insulation

SPF can be used to fill the rafter cavities completely to the underside of the sheathing, providing both air-barrier

and insulation services. Closed-cell SPF is typically a Class II vapor retarder, meaning no additional vapor control is required. Open-cell SPF is typically a Class III vapor retarder, meaning an additional Class II vapor retarder must be installed inboard of the SPF to reduce vapor diffusion through the assembly. Note that depending on the permeability of the roofing underlayment and roofing material, this approach can reduce the drying potential of the roof sheathing, creating greater risk in the event of a roof leak.

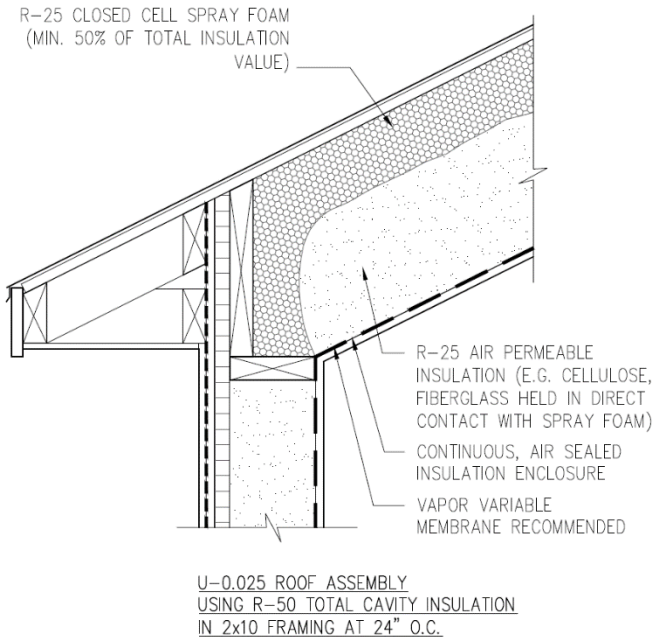


Figure 2.28 – “Flash and batt” hybrid cavity insulation

Rather than filling the entire rafter cavity with SPF insulation, a “flash” of closed-cell SPF equal to 50% of the total insulation value can be installed to move the dew point inside of the SPF while providing air sealing and vapor control services, with the rest of the cavity filled with fibrous batt or dense-pack insulation. Air sealing should still be provided inboard of the insulation cavity, and a vapor-variable membrane is recommended here to reduce vapor diffusion into the cavity while still providing an inward drying pathway.

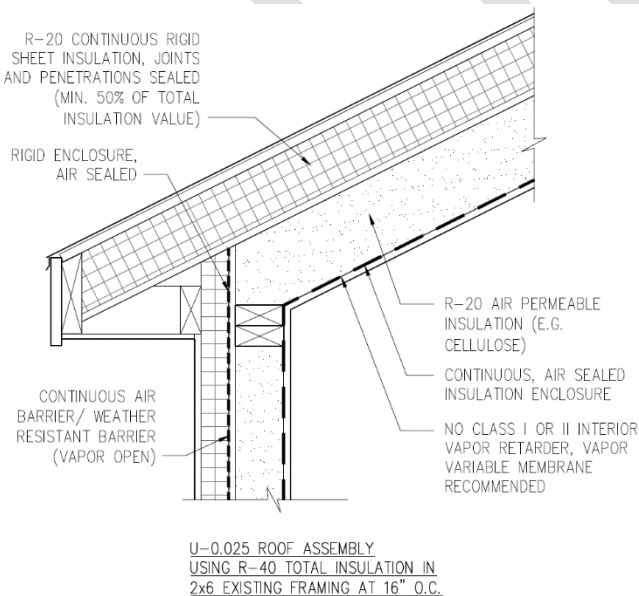
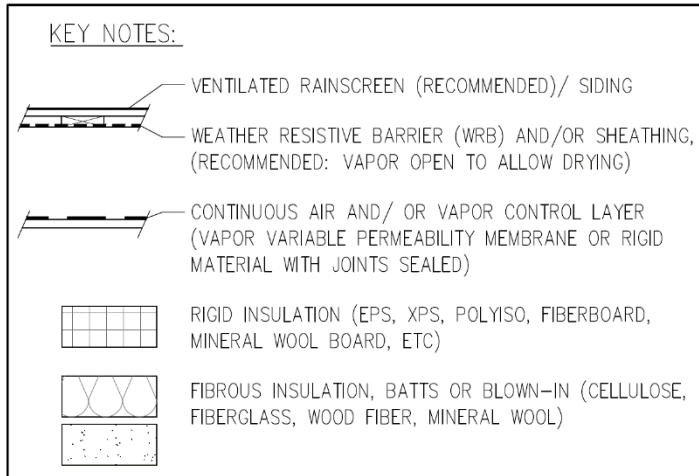


Figure 2.29 – Exterior rigid board

Like the exterior continuous insulation approach for a wall, this similar approach can be used over a roof, with the same recommendation for locating 50% of the total insulation value in the rigid insulation. Since roof R-values are required to be greater than wall R-values, this means the rigid insulation will need to be thicker, often using multiple layers. In this case, the seams should be staggered and all seams and penetrations should be sealed. Like the similar wall condition, a drying pathway to the interior should be provided by avoiding the use of Class I or II vapor retarders on the inside of the assembly.



2.4 Resources

The resources provided below can be used to further develop your understanding of building science concepts and improve the detailing of your projects:

Bailes III, Allison A.: *A House Needs to Breathe...Or Does It?* Bright Communications, LLC, 10/17/22. *An exploration of the fundamental principles of building science applied in residential construction.*

Building America Solution Center, Office of Energy Efficiency and Renewable Energy, U.S. Department of Energy. <https://bascc.pnnl.gov/>. *A free information portal providing a wide range of information, tools, guidebooks, and code assistance.*

Building Science Corporation: <https://www.buildingscience.com>. *The website for Building Science Corporation provides a searchable library of building science-related content.*

Krigger, John T.: *Residential Energy: Cost Savings and Comfort for Existing Buildings (7th Edition)*. Saturn Resource Management, Inc., 4/1/24. *A premier building science textbook frequently referenced by energy raters and other professionals as a go-to resource.*

Lstiburek, Joe: *Builder's Guide to Cold Climates*. Building Science Press, 2022. <https://buildingscience.com/bookstore/books/builders-guide-cold-climates>. *A definitive guide to the application of building science principles in cold-climate construction.*

Racusin, Jacob Deva: *Essential Building Science: Understanding Energy and Moisture in High Performance House Design*. New Society Publishers, 2017. *A guide to the application of building physics principles in residential high performance construction.*

Chapter 3

.....

Basic Requirements

The Residential Energy Code specifies basic minimum requirements that are mandatory for all buildings listed in the Introduction under “Buildings That Must Comply.” The basic requirements for the residential energy code are summarized in Table 3-1 below.

This chapter does not, however, specify minimum insulation R-values or maximum glazing or door U-values, which are detailed in Chapters 6 through 8.

DRAFT

Table 3-1. Basic Requirements - Summary

| Vermont Residential Building Energy Code | | |
|--|---|--|
| Basic Requirements - Summary | | |
| 1 | Air Sealing and Air Leakage | Seal all joints, access holes and other such openings in the building envelope, as well as connections between building assemblies. Air barrier installation must follow criteria established in Section 3.1a. Refer to Table 3-2 for a summary. Air leakage must be tested, using a blower door test by a certified professional. Air leakage rates must not exceed 0.15 CFM50/Sq. Ft. Building Shell area including all six sides of the building (~2 ACH50). Refer to Section 3.1b for details. |
| 2 | Vapor Retarder | Provide an interior vapor retarder appropriate to insulation strategy; refer to Section 3.2. |
| 3 | Duct Location, Insulation, and Sealing | All ducts and air handlers shall be located within the conditioned space of the building. All ducts, air handlers, and filter boxes shall be sealed. Refer to Section 3.4e for details. |
| 4 | HVAC Systems: Efficiency & Balancing | HVAC heating and cooling systems must comply with minimum federal efficiency standards for Climate Zone 6. |
| 5 | Equipment Sizing | Building heating and cooling loads must be calculated in accordance with ACCA Manual J or other approved calculation methodologies. Heating and cooling equipment must be sized in accordance with ACCA Manual S (ref. RBES Section R403.7), which includes restrictions on oversizing |
| 6 | Programmable Thermostat | The thermostat controlling the primary heating or cooling of the dwelling must be programmable, with exemptions for radiant systems on a dedicated zone, cold-climate heat pumps not designed for set-backs and Wi-Fi or "smart" internet-connected thermostats. Refer to RBES Section R403.1.1 for details. |
| 7 | Fireplaces and Solid Fuel-Burning Appliances | All fireplaces and solid fuel-burning appliances must have tight-fitting, gasketed metal, glass or ceramic doors with compression closure or compression latch system. Combustion air supply must be provided directly from outdoors |
| 8 | Exhaust Fans and Appliances | Exhaust dampers are required for kitchen, bath and dryer fans. Makeup air is required for exhaust systems capable of 400 cubic feet per minute (CFM) or greater. Dampers with positive closures shall be installed to keep outside air from entering the exhaust duct when the system is not operation (exception: mechanical ventilation systems designed for continuous operation). |
| 9 | Ventilation | All homes must have a whole house balanced ventilation system. Ventilation fans in bathrooms containing a bathtub or shower and not included in the whole house ventilation system shall be sized to provide 50 CFM intermittent or 20 CFM continuous exhaust capacity. See Chapter 4 for details. |
| 10 | Snow Melt System Controls | Snow and ice-melting systems must include automatic controls capable of shutting off the system when the pavement temperature is above 45°F (10°C) and precipitation is not falling or manual control that will allow shutoff when the outdoor temperature is above 40°F (4.8°C). |
| 11 | Electric Systems | Each new building, except for individual multifamily units, shall be supplied with at least 200 amp electrical service in anticipation of increased electrical services that will need to be provided in the future. In most cases, each unit of a multifamily dwelling must have a separate electric meter. |
| 12 | Mechanical System Piping Insulation and Circulating Hot Water Systems | Mechanical system piping capable of carrying fluids above 105°F (41°C) or below 55°F (13°C) must be insulated to a minimum of R-4 and must be located within the building thermal envelope. Circulating hot water systems shall automatically turn off the hot water circulating pump when the water in the circulation loop is at the desired temperature and when there is no demand for hot water. |
| 13 | Lighting | All permanently installed lighting fixtures, excluding kitchen appliance lighting fixtures, shall contain only high-efficacy lighting sources. |
| 14 | Electric Heating Equipment | Generally speaking, heating with electric-resistance heating equipment is prohibited. Heat pumps shall be certified cold-climate heat pumps only and shall have controls that, except during defrost, prevent supplemental electric heating when the heat pump compressor can meet the heating load. See section 3.4b for additional details. |
| 15 | Pools, Hot Tubs and Spas | All swimming pools must have a time clock to control the pump. Heated swimming pools must have both a heater on/off switch in an accessible location and a pool cover. Heaters may not have continuously burning pilot lights. |
| 16 | Electric Vehicle Charging | One parking space capable of accommodating a Level 2 charger or one space with a Level 2 charger is required per dwelling unit or the number of parking spaces provided, whichever is less. Additional details and exceptions can be found in Section 3.9. |
| 17 | Certification | Complete a Vermont Residential Building Energy Standards (RBES) Certificate for each dwelling. Affix the RBES certificate to the electrical panel without covering or obstructing visibility of other labels. Send one copy to the Vermont Public Service Department and file one copy with the Town Clerk of the town in which the property is located. |

Building Envelope

Section 3.1a

Air Leakage

A continuous, durable air barrier must be installed in the building envelope. All exterior joints, breaks, seams or penetrations in the building envelope that are sources of air leakage must be either sealed with durable caulking materials, closed with gasketing systems, taped or otherwise sealed. This includes windows and other (structural) interruptions. Refer to Figure 2.3 for an illustration of common methods used to create continuous air barriers relating to these details. **Air sealing must be verified by a blower door test (see Section 3.1b).**

An air barrier is a durable solid (non-porous) assembly that blocks air flow through the *building thermal envelope* and its assemblies. Air barriers must be continuous, sealed at all joints, penetrations, and interruptions using durable sealants intended for such use and compatible with all adjacent materials, and able to resist pressures without displacement or damage.

Consider that flexible air barriers may be less effective and durable than rigid air barriers. If flexible air barriers are used, they must be fully sealed at all seams and edges and supported per manufacturer's installation instructions. Flexible air barriers must not be made of kraft paper, or other materials that are easily torn. Note that typical installations of 'house wraps' are not detailed in a manner that would allow them to be effective air barriers. If polyethylene is used as an air barrier, its thickness must be ≥ 6 mil and it must be properly supported. Air-permeable insulation must not be used as an air sealing material; when installed in vertical walls, sloped ceilings and floors that are part of the thermal envelope, it must be enclosed on all six sides and in contact with a durable air barrier. Open-cell or closed-cell foam must have a finished thickness ≥ 5.5 in. or 1.5 in. respectively, to qualify as an air barrier unless the manufacturer indicates otherwise.

In addition to the above guidance, Table 3-2 details the list of air sealing requirements that, collectively, will reduce the blower door test leakage result. While all of the following air leakage checklist items must be in place, compliance with air sealing requirements is ultimately determined with blower door testing

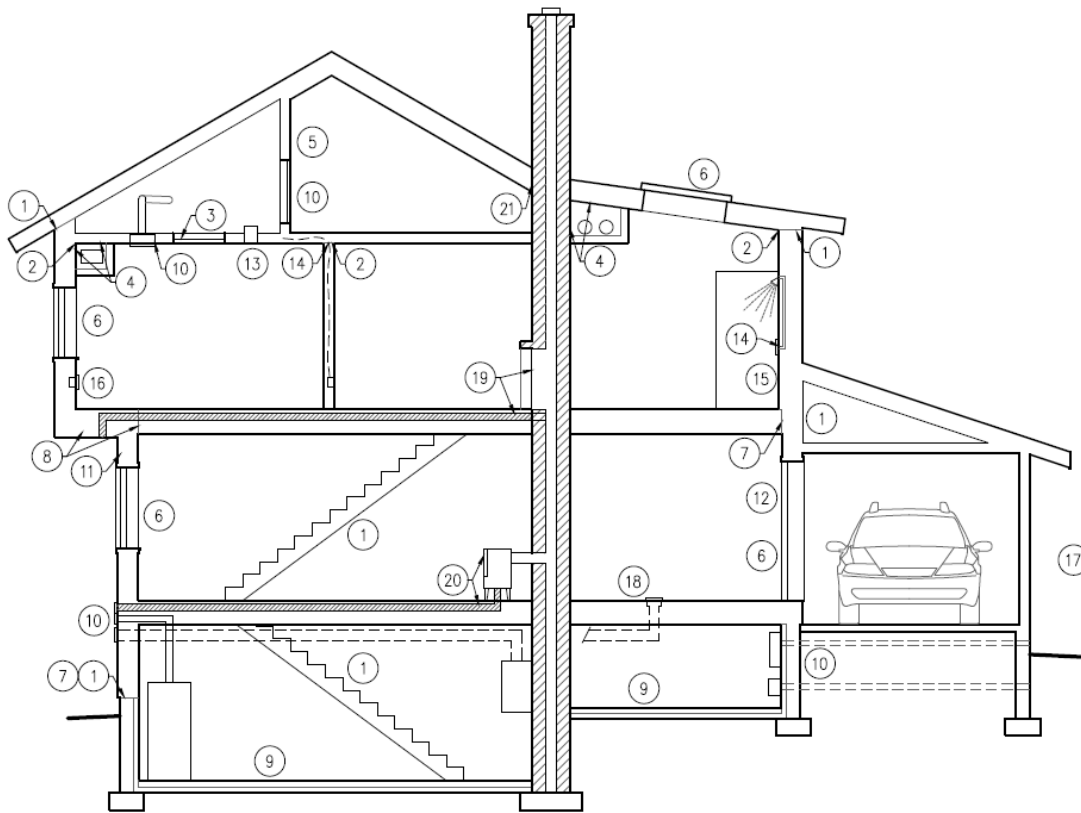
DRAFT

Table 3-2. Air Sealing Checklist

| Air Sealing Checklist - [with limited insulation details in brackets] | | |
|---|--|---|
| 1 | Walls | The junction of the foundation and sill plate must be sealed. The junction of the top plate and the top of exterior wall sheathing must be sealed. [Cavities within corners and headers of frame walls must be insulated by completely filling the cavity with a material having a thermal resistance of $\geq R-3$ per inch.] Exterior thermal envelope insulation for framed walls must be installed in substantial contact and continuous alignment with the air barrier. [Exterior thermal envelope insulation for framed walls that is air permeable must be enclosed on all six sides and in contact with a durable air barrier.] Air barrier and insulation requirements also apply for cases such as staircase framing at exterior walls (see Figure 3-1), porch/garage roof connections (see Figure 3-1), stepped foundation walls, and service entrances (holes). |
| 2 | Ceiling/attic | Top plates, wall-to-ceiling connections, and all penetrations into the attic/ceiling are sealed. A top-side air barrier above the flat insulation is not required in a flat attic. |
| 3 | Attic hatch or door | Access openings, drop down stairs or knee wall doors to unconditioned attic spaces must be sealed, insulated and gasketed for air-tight fit. [Insulate to surrounding R-values.] |
| 4 | Soffit | The air barrier in any dropped ceiling/soffit must be aligned with (in contact with) the insulation and any gaps in the air barrier must be sealed. The insulation must be enclosed on at least five sides and in contact with a durable, interior air barrier. |
| 5 | Knee Wall | Knee walls must be sealed. When part of the thermal envelope, knee wall insulation must be enclosed on all six sides and in contact with a durable, interior air barrier. See Figure 2.19 for one method to meet this requirement. |
| 6 | Windows, doors and skylights | The space between window/door jambs and framing, and skylights and framing must be sealed with minimally-expanding foam, caulk with backer rod and sealant or flexible membranes supported by or adhered to rigid air barrier material. |
| 7 | Rim joist / sill or bottom plate | Rim joists must be insulated and must include an exterior air barrier. Junctions of the foundation and sill plate, sill plate and rim band, and rim band and subfloor must be sealed. When air permeable insulation is installed, a durable, interior air barrier must be installed at the rim joist. Penetrations through the bottom plates should be sealed. [Rim joists should be insulated so that the material maintains permanent contact with the exterior rim board]. |
| 8 | Cantilevered and overhanging floors (including above garage) | The air barrier must be installed at any exposed edge of insulation. Floor framing cavity insulation must be installed to maintain permanent contact with the underside of the subfloor decking. It is highly recommended that floor framing cavity insulation also be in permanent contact with the top side of the sheathing or continuous insulation installed on the underside of the floor framing. See Figure 2.18 for one method to meet this requirement. |
| 9 | Crawl space/ Basements | Exposed earth in unvented crawl spaces or basements must be covered with a Class I vapor retarder with overlapping joints taped. [When used instead of installing a vapor barrier integral with the floor insulation, the vapor barrier must be permanently attached to the crawlspace/ basement walls.] |
| 10 | Shafts, penetrations | Duct and flueshafts, utility penetrations, and other penetrations to exterior or unconditioned space must be sealed and allow for expansion, contraction, and mechanical vibration. Doors or hatches in knee walls opening to exterior or unconditioned space must be insulated to surrounding insulation R-value levels and gasketed. |
| 11 | Narrow cavities | Narrow cavities of 1 inch or less that cannot be insulated shall be air sealed and filled with insulation that readily conforms to the available space. |
| 12 | Garage separation | Air sealing must be provided between the garage and conditioned spaces. Doors connecting garage to living space must be insulated and air sealed as an exterior door. |
| 13 | Recessed lighting and appliances | Recessed light fixtures and other appliances (speakers, exhaust fans, light shafts, etc.) installed in the building thermal envelope must be ICAT (Insulation Contact and Air Tight) rated or airtight labeled and sealed with a gasket or caulk between the housing and the interior wall or ceiling cover. Fixtures and appliances must maintain required clearances of not less than $\frac{1}{2}$ " from combustible materials and not less than 3" from insulation material, or as required by manufacturer. |
| 14 | Plumbing and wiring | All holes created by wiring, plumbing, or other penetrations in the air barrier shall be air sealed. [Insulation shall be installed to fill the available space and surround the penetrations unless the required R-value can be met by installing insulation and air barrier systems completely to the exterior side of the obstructions. Insulation should not be installed on the interior of piping. Batt insulation should be cut neatly to fit around wiring and plumbing in exterior walls, or insulation that on installation readily conforms to available space should extend behind piping and wiring and be in full contact with air barrier.] |

| | | |
|----|---|--|
| 15 | Shower or tub on exterior wall | Exterior walls adjacent to showers and tubs must have insulation filling any gaps or voids between those walls and unconditioned space. There must be a rigid durable air barrier separating the exterior wall from the shower or tub when using air-permeable insulation. |
| 16 | Electrical/phone box on exterior wall | The air barrier must be installed behind electrical or communication boxes, or air-sealed boxes must be installed. [Insulation should completely fill voids between the box and exterior sheathing.] |
| 17 | Common wall between attached homes or units | Whenever continuity of the building thermal envelope is broken at walls separating dwelling units in Group R-2 building, including common, party and fire walls, such walls must be insulated to a minimum of R-10 on each side of the break in insulation continuity. The air barrier must be installed in common walls between dwelling units in order to completely isolate each unit from the other. Common walls must be sealed at junctions with outside walls and at the top pressure plane of the house. |
| 18 | HVAC register boots | HVAC register boots that penetrate the building thermal envelope must be sealed to the subfloor or drywall. |
| 19 | Fireplace | A durable air barrier must be installed in contact with the insulation surrounding fireplaces. Fireplace must have compression/tight-fitting metal glass or ceramic doors. Combustion air must be supplied directly from the outdoors. |
| 20 | Woodstove | Woodstove must have compression/tight-fitting metal glass or ceramic doors. Combustion air must be supplied directly from the outdoors. |
| 21 | Chimney shaft or flue | Chimney or flue shafts opening to exterior or unconditioned space must be sealed. |

Figure 3-1. Air sealing checklist corresponding details



3.1b

Air Sealing Verification with Blower Door Test

Building envelope air tightness shall be tested and verified as having an air leakage rate of 0.15 CFM50/Sq. Ft. of building shell area of all six sides of the building; this is roughly the equivalent of 2 air changes per hour at 50 Pascals (ACH50).

“All six sides of the building” refers to the exterior walls (front, back, and two sides – above and below grade), the building roof or ceiling (whichever is part of the thermal shell), and the building slab or basement floor. Note, a building can have more than four sides, and all exterior wall surface areas should be accounted for when using the building shell area to calculate normalized air leakage rates. Normalizing air leakage using building shell area, as opposed to the building volume (which is the variable used to normalize leakage results with the ACH50 metric), provides a more accurate picture of the leakage associated with the building envelope than ACH50 measurements and is equally challenging for small and large buildings. Using CFM50/Sq. Ft. will also help focus attention on specific envelope leaks during the testing process. Buildings with simple architectural designs are likely to perform better than buildings with complex designs or wide footprints.

Air leakage testing and verification must be conducted by an applicable Building Performance Institute (BPI) Professional, a Home Energy Rating System (HERS) Energy Rater, HERS Field Inspector, an Air Barrier Association of America (ABAA) Whole Building Airtightness Technician, or a Vermont Department of Public Service approved air leakage tester. A written report of the results of the test must be signed by the party conducting the test and the result must be recorded on the RBES Certificate for the building.

Single family attached homes -for example duplexes and side-by-side row houses or townhomes - must be tested/verified individually.

3.1c

Blower Door Test Procedure

Tested air leakage must not exceed 0.15 CFM50/Sq. Ft. of the six-sided building shell area when tested with a blower door at a pressure of 50 Pascals. Testing must occur after rough-in and after installation of penetrations of the building envelope, including penetrations for utilities, plumbing, electrical, ventilation and combustion appliances. Testing shall be conducted in accordance with ANSI/RESNET/ICC 380, ASTM E779 or ASTM E1827. The following protocol must be followed in preparing the building envelope for testing:

1. Exterior windows and doors, fireplace and stove doors shall be closed, but not sealed, beyond the intended weatherstripping or other infiltration control measures.
2. Dampers including exhaust, intake, makeup air, backdraft and flue dampers shall be closed, but not sealed beyond intended infiltration control measures.
3. Interior doors, where installed at the time of the test, shall be open.
4. Exterior or interior terminations for continuous ventilation systems shall be sealed.
5. Heating and cooling systems, where installed at the time of the test, shall be turned off.
6. Supply and return registers, where installed at the time of the test, shall be fully open.
7. Plumbing and drainage traps shall be filled with water as normally found, but not otherwise sealed.

Air density corrections should be made to account for air temperature and altitude based on ANSI/RESNET/ICC 380, ASTM E779 or ASTM E1827 test standards.

3.1d

Air Leakage Testing Reporting

Air leakage testing shall be reported on the RBES certificate in units of A) CFM50, B) ACH50, and C) CFM50 per square foot of building thermal shell area which includes all six (6) sides of the building.

CFM50 = Cubic feet per minute at 50 Pascals (this is the value being measured by the blower door gauge when the home is either pressurized or depressurized to 50 Pascals)

ACH50 = CFM50 x 60 / Volume of house, in cubic feet

CFM50/SF = CFM50 / Total thermal shell area[†]

[†]The square footage to be used for the CFM50/SF calculation is based on *all six sides* of the *building thermal envelope* including the bottom side whether it is in contact with the ground (slab) or not (floor on piers). The building thermal shell area includes unfinished basements, exterior walls of storage/utility rooms, insulated knee walls and slanted ceilings that are part of the *building thermal envelope*, even if the space is not heated. Use exterior measurements to calculate thermal shell area.

Adiabatic surfaces are excluded, except when modeling individual multifamily dwellings. The volume is calculated as the volume of space within the building thermal shell area as defined above.

Example, ACH50: A home has a footprint of 800 sq. ft (20 ft x 40 ft), with a basement plus 2 stories above grade. Each level has 8 ft ceilings. The blower door / airtightness test measured 550 CFM50. The home's square footage is 3 x 800 sq. ft. = 2400 sq. ft. Its volume is 3 x (800 sq. ft x 8 ft) = 19,200 cu. ft.

ACH50 = CFM50 x 60 / Volume = 550 CFM50 x 60 / 19,200 = **1.72 ACH50**

Example, CFM50/SF:

For the CFM50/shell sq. ft. calculation, you need to figure out the building shell area, which is all 6 sides of the building (4 walls, ceiling, and bottom floor). Using the same home mentioned above, the 20 ft x 40 ft building has a 120 ft perimeter that is 26 ft high (3 levels of 8 ft each plus the 1 ft band joists between the basement/first floor and the first/second floor) so there are 3120 sq. ft of walls, plus 800 sq. ft of basement floor and 800 sq. ft of flat ceiling. This adds up to 4720 sq. ft of shell area. The calculation, then, is:

CFM50/SF = 550 CFM50 / 4720 sq. ft = **0.117 CFM50/SF**

3.2

Unvented Attics

Unvented attic assemblies (spaces between the ceiling joists of the top story and the roof rafters) and unvented enclosed roof framing assemblies (ceilings applied directly to the underside of the roof framing members/rafters) are permitted in one- and two-family homes and multiple single-family dwellings (townhouses) if all the following conditions are met:

1. The unvented attic space is completely contained within the building thermal envelope
2. No Class I interior vapor retarders are installed on the ceiling side (attic floor) of the unvented attic assembly or on the ceiling side of the unvented enclosed roof framing assembly.
3. Where wood shingles or shakes are used, a minimum 1/4 inch (6 mm) vented air space separates the shingles or shakes and the roofing underlayment above the structural sheathing.
4. Any air-impermeable (e.g., spray foam) insulation must be a Class II vapor retarder or must have a Class II vapor retarder coating or covering in direct contact with the underside of the insulation.
5. One of the items below must be met, depending on the air permeability of the insulation directly under the structural roof sheathing. See Figure 2.27, Figure 2.28, and Figure 2.29 for examples.
 - a) *Air-impermeable (e.g., spray foam) insulation only.* Insulation must be applied in direct contact with the underside of the structural roof sheathing.
 - b) *Air-permeable (e.g., fiberglass or cellulose) insulation only.* In addition to the air-permeable insulation installed directly below the structural sheathing, rigid board sheet insulation should be installed directly above the structural roof sheathing for condensation control. For reference, the International Residential Code requires at least R-25 rigid board insulation in Vermont's Climate Zone 6 (Ref. IRC 2018 Table R806.5) for unvented roof assemblies in this scenario.
 - c) *Air-impermeable and air-permeable insulation.* The air-impermeable (e.g., spray foam) insulation should be applied in direct contact with the underside of the structural roof sheathing for condensation control. For reference, the International Residential Code requires at least R-25 air-impermeable insulation in Vermont's Climate Zone 6 (Ref. IRC 2018 Table R806.5) for unvented roof assemblies in this scenario. The air-permeable (e.g., fiberglass or cellulose) insulation must be installed directly under the air-impermeable (e.g., spray foam) insulation.

Note that IRC 2018 provides for a calculation-based alternative to these 3 choices above, if sufficient rigid board or sheet insulation is installed directly above the structural roof sheathing to maintain the monthly average temperature of the underside of the structural roof sheathing above 45°F (7°C). For calculation purposes, an interior air temperature of 68°F (20°C) is assumed and the exterior air temperature is assumed to be the monthly average outside air temperature of the three coldest months.

3.3

Materials and Equipment Information

Insulation R-values and glazing and door U-factors must be clearly marked on the building plans or specifications. If two or more different insulation levels exist for the same component, record each level separately on the plans or specifications. (For example, if the walls adjacent to the garage have less insulation than the other walls, you must note both insulation levels.)

Insulation R-values and glazing and door U-factors must also be visible for each piece of the building thermal envelope. Note that the R-value of the insulation is often pre-printed directly on the insulation or can be determined from a striping code. Window U-factors are often included on the manufacturer label posted directly on the window. Windows and doors without visible U-factor labels must use default values from Tables B-1 and B-2 when assessing code compliance via Packages Plus Points, *REScheck*[™], or ERI/HERS Rating

For blown or sprayed insulation, the initial installed thickness, the settled thickness, the coverage area, and the number of bags must be clearly posted at the job site. For sprayed polyurethane foam (SPF) insulation, the installed thickness of the areas covered, and R- value of installed thickness shall be listed on the certification. The thickness of blown-in or sprayed fibrous attic insulation shall be written in inches on markers that are installed at least one for every 300 square feet throughout the attic space. The markers shall be affixed to the trusses or joists and marked with the minimum initial installed thickness with numbers not less than 1" in height, facing the attic access opening.

Equipment efficiency make, and model number should be marked on the plans or specifications and manufacturer manuals for all installed heating and cooling equipment and service water heating equipment must be provided.

3.4

Vapor Retarders

Effort must be made to protect insulated cavities from airborne water vapor and condensation. Air sealing the interior face of the assembly, controlled mechanical ventilation (targeting no less than 30% relative humidity during the winter season), exterior continuous insulation and proper consideration of the vapor permeance of materials are all design elements that can contribute to this protection. See Chapter 2 Moisture Management for Durable Buildings for additional information, including Table 2.1.

There are three major classes of vapor retarders. See Table 3-3 below.

Table 3-3. Vapor Retarder Classes and Examples

| Vapor Retarder Class ² | Perm Rating (Dry Cup) | Description | Examples of Materials |
|-----------------------------------|-----------------------|--------------------------------------|---|
| Class I | 0.1 perm or less | Vapor impermeable or "Vapor Barrier" | Rubber membrane, sheet polyethylene, glass, foils |
| Class II | 0.1 -1.0 perm | Vapor semi- impermeable | Oil-based paint, Kraft- faced batt, vinyl wall coverings, stucco |
| Class III | 1.0 – 10 perm | Vapor semi-permeable | Plywood, OSB, EPS, XPS, most latex paints, heavy asphalt-impregnated building paper, wood board sheathing |
| Vapor Open | >10 perm | Vapor permeable | Unpainted gypsum board, unfaced fiberglass, cellulose, many "housewraps" |

- **Class I or II vapor retarders** are required on the interior side of frame walls.
 - Exceptions:
 - Basement/concrete foundation walls.
 - Below grade portion of any wall.
 - Construction where moisture or its freezing will not damage the materials.
- **Class III vapor retarders** on the interior side of frame walls shall be permitted where any one of the following three conditions is met:
 1. Vented cladding over the following sheathing types:
 - a. Fiberboard;
 - b. Gypsum;
 - c. Plywood (CDX or comparable); or
 - d. Solid wood
 2. Insulated sheathing with R-value 7.5 min. over 2x4 wall
 3. Insulated sheathing with R-value 11.25 min. over 2x6 wall

Low permeability exteriors – Where a Class II vapor retarder is used on the interior side of frame walls, in combination with a low permeability insulating sheathing installed as continuous insulation on the exterior side of frame walls, the Class II vapor retarder shall have a vapor permeance greater than 1 perm when measured by ASTM E96 water method (Procedure B). Use of a Class I interior vapor retarder in frame walls with a Class I vapor retarder on the exterior side (e.g. sheet polyethylene on interior and foil-faced foam board on exterior) shall require an engineering approved design. See Chapter 2 Moisture Management for Durable Buildings for details on moisture and control approaches to minimize moisture risk.

²Test Procedure for vapor retarders: ASTM E-96 Test Method A (the desiccant method or dry cup method)

Section 3.5

Heating and Cooling

3.5a

Heat Pumps

Heat pumps must be certified “cold-climate heat pumps”⁸ or with an inverter-driven, variable capacity compressor that is designed to provide full heating heat pump capacity and having a minimum COP of 1.75 or greater at an outside air temperature of 5°F. Heat pumps shall not have integrated electric-resistance heat other than that provided for frost control. Electric resistance heat as part of the heating system design, only as permitted per Section 3.4b.

3.5b

Electric Resistance Heat

Heating with electric resistance heating equipment is prohibited except:

1. When replacing existing electrical resistance units;
2. In limited areas where other heating sources are cost-prohibitive or impractical, such as in bathrooms or a stairwell or other areas distant from the heat distribution system;
3. In buildings with cold-climate heat pumps as the primary heating system, provided that:
 - a. The supplemental electric resistance heat is controlled to prevent it from operating at an outside air temperature of 5°F or higher
4. Multifamily buildings with heating loads ≤ 6.0 Btu/hour/square foot at design temperature.

Note: Buildings served by the Burlington Electric Department (BED) must receive approval from BED before installing supplemental electric resistance heating equipment.

⁸ Qualified “cold climate heat pumps” are listed on Efficiency Vermont’s Qualified Products List at <https://qualifiedproducts.encyvermont.com/evt/searchgroups?incomeQualified=False>

3.5c

Equipment Sizing

A heating design load calculation (and when applicable, a cooling design load calculation) for the purpose of sizing these systems must be performed by the HVAC contractor, supplier, designer, rater, consultant or engineer to ensure proper equipment sizing. ACCA Manual J, or other *approved* heating and cooling load calculation methods, are acceptable for determining design loads. Heating and cooling (when applicable) equipment must be sized according to ACCA manual S. Thermal design parameters must be within specified limits. A maximum interior design temp of 72°F is to be used for heating calculations (minimum interior design temp of 75°F for cooling). Winter design temperature used depends on location. Minus 11°F may be used as a default for Vermont. Design temperature conditions must be recorded on the RBES certificate. See R302 in RBES for details and exceptions.

3.5d

Duct Placement and Insulation

All ducts and air handlers must be located within the conditioned space of the building. For this reason, there are no insulation requirements for ducts in the 2024 RBES.

3.5e

Building Cavities as Ducts

Building framing cavities shall not be used as ducts or plenums.

3.5f

Duct Sealing and Testing

- All ducts, air handlers, and filter boxes shall be sealed at the joints and seams. There are no duct testing requirements because all ducts are required to be located within the building's thermal envelope.

3.5g

Temperature Controls

At least one thermostat shall be provided for each separate heating and cooling system.

The thermostat controlling the primary heating or cooling system of the dwelling unit shall be capable of controlling the heating and cooling system on a daily schedule to maintain different temperature set points at different times of the day and different days of the week. This thermostat shall include the capability to set back or temporarily operate the system to maintain zone temperatures down to 55°F (13°C) or up to 85°F (29°C). The thermostat shall initially be programmed by the builder or HVAC contractor with a heating temperature set point no higher than 70°F (21°C) and a cooling temperature set point no lower than 78°F (26°C). Adjustments to these settings for the elderly, disabled or those with special needs is permissible.

The following exceptions to the thermostat requirement are allowed as long as a 5-wire connection to the thermostat location is provided:

1. Radiant floor, wall, ceiling and/or beam system on dedicated zone.

2. Wifi or “smart” Internet-connected thermostats.
3. Cold climate heat pumps not designed for setbacks. (In homes with cold climate heat pumps as the sole heating source, no 5-wire connection is required.)

Heat pumps shall have controls that, except during defrost, prevent supplementary electric heat operation where the heat pump can meet the heating load. Ductless heat pumps shall not have integrated electric resistance heat other than that provided for frost control.

Hot water boilers that supply heat to the building through one- or two-pipe heating systems must have an outdoor setback control that adjusts output water temperature based on the outdoor temperature.

3.5h

HVAC Piping Insulation

All HVAC piping (such as in hydronic heating systems) conveying fluids at temperatures greater than 105°F or chilled fluids at less than 55°F must be located within the building thermal envelope and insulated to a minimum of R-4. Pipe insulation is not required for piping installed within HVAC equipment.

Protection of piping insulation

Piping insulation exposed to weather shall be protected from damage, including that caused by sunlight, moisture, equipment maintenance and wind, and shall provide shielding from solar radiation that can cause degradation of the material. Adhesive tape shall not be permitted.

Section 3.6

(Potable) Water Heating

3.6a

Domestic Hot Water Pipe Insulation

Insulation for service hot water pipe with a minimum thermal resistance (R-value) of R-4 shall be applied to the following:

1. Piping 3/4” and larger in nominal diameter located inside the conditioned space.
2. Piping serving more than one dwelling unit.
3. Piping located outside the conditioned space.
4. Piping from the water heater to a distribution manifold.
5. Piping located under a floor slab.
6. Buried piping.
7. Supply and return piping in circulation and recirculation systems other than cold water pipe return demand recirculation systems.

3.6b

Hot Water Circulation and Temperature Maintenance Systems

Circulation Systems. Where installed, heated water circulation systems must be provided with a circulation pump. The system return pipe must be a dedicated return pipe or a cold water supply pipe. Gravity and thermosyphon circulation systems are prohibited. Controls for circulating hot water system pumps shall automatically turn off the pump when the water in the circulation loop is at the desired temperature and when there is no demand for hot water. The controls shall limit the temperature of the water entering the cold-water piping to not greater than 104°F (40°C).

Heat trace systems. Controls for electric heat trace systems must automatically adjust the energy input to the heat tracing to maintain the desired water temperature in the piping in accordance with the times when heated water is used in the occupancy.

Demand recirculation systems. A water distribution system having one or more recirculation pumps that pump water from a heated water supply pipe back to the heated water source through a cold-water supply pipe must be a demand recirculation water system. Pumps must have controls that comply with both of the following:

1. The control must start the pump upon receiving a signal from the action of a user of a fixture or appliance, sensing the presence of a user of a fixture or sensing the flow of hot or tempered water to a fixture fitting or appliance.
2. The control must limit the temperature of the water entering the cold-water piping to 104°F (40°C).

3.6c

Swimming Pools, Hot Tubs and Spas

All heated pools, hot tubs, and spas must be equipped with an on/off pool heater switch mounted for easy access (in addition to the circuit breaker for power to the heater). Heaters fired by natural or LP gas cannot have continuously burning pilot lights. Outdoor heated pools and hot tubs require a vapor-retardant pool cover of at least R-12 unless over 75% of the heating energy is from site-recovered energy, such as from a heat pump or solar energy source.

All swimming pool pumps must be equipped with a time clock that can automatically turn off heaters and pumps according to a preset schedule, except where public health standards require 24-hour operation or where pumps operate solar-and-waste-heat recovery pool heating systems.

Section 3.7

Electrical

In most cases, each individual dwelling unit shall have a separate electrical meter. **Exception:** Buildings where a majority of the living units serve tenants at or below 80% of the area median income.

Section 3.7a

Electrical Panels

Each new building, except for individual multifamily units, shall be supplied with at least 200 amp electrical service in anticipation of increased electrical services that will be needed in the future.

Section 3.8

Lighting

All permanently installed lighting fixtures, excluding kitchen appliances, shall contain only high-efficacy lighting sources.⁹

Section 3.8a

Multifamily Lighting

Multifamily buildings three-stories or less with common areas, stairwells, vestibules, lobbies, parking garages, and exterior parking areas must meet the lighting power density (LPD) specifications of the Vermont Commercial Building Energy Standards (CBES).

Section 3.9

Electric Vehicle Charging Stations

- One *Electric Vehicle Charging – Level 2 Capable* parking space or one space with a Level 2 Electric Vehicle Charging station is required for each new dwelling unit or the number of parking spaces provided, whichever is less. A *Level 2 Capable* parking space is one in which the electric panel has space for at least one 40-amp branch circuit to be provided to the garage or exterior of the building to accommodate a future Level 2 (240 Volt) Electric Vehicle Charging station. A conduit or other unobstructed path to easily run a future wire to the parking spot must be in place within five feet of the parking space.

Exemptions: The following types of parking spaces do not need to comply:

1. Parking spaces intended exclusively for storage of vehicles for retail sale or vehicle service.
2. Parking spaces that are separated from the meter by a public right-of-way, such as a road.
3. Parking spaces which are limited to parking durations of less than an hour.
4. EV-capable spaces are not required where no parking spaces are provided.

For *multifamily building* garage or covered parking, the builder or designer must:

- provide on electrical drawings the appropriate sized pathway to the building electrical room to accommodate a future electrical upgrade for Level 2 EVSE electric vehicle charging;
- provide adequate wall and floor space in the building electrical room for future EV charging related electrical equipment;
- provide the appropriate sized pathways to exterior on-grade surface parking spaces for future Level 2 EVSE electric vehicle charging;
- provide a line diagram on the electrical drawings demonstrating a pathway for future Level 2 EVSE electric vehicle charging.

The quantity of future Level 2 EVSE electric vehicle charging stations shall be as required by Table R404.3.

⁹ High-Efficacy Lamps are defined as Light Emitting Diode (LED) or compact fluorescent lamps, T-8 or smaller diameter linear fluorescent lamps, or lamps with a minimum efficacy of not less than 65 lumens per watt; or light fixtures of not less than 55 lumens per watt. In determining the number or percent of lamps, each replaceable lamp (or light string) connected to a permanently installed lighting fixture shall count as one lamp.

DRAFT

Chapter 4

.....

Ventilation and Combustion Safety Requirements

Section 4.1

Ventilation

The Vermont Residential Building Energy Code requires all newly constructed homes, to be mechanically ventilated with a whole-house balanced ventilation system. This requirement does not apply to homes undergoing additions, alterations, or repairs as unaltered portions of the existing building are not required to comply with the code. The whole house balanced ventilation systems shall have a minimum Sensible Recovery Efficiency (SRE) of 70% and fan efficiency of 1.2 cfm/Watt or better. There are also requirements for combustion equipment aimed at reducing the likelihood of flue gas venting problems. This chapter provides details on these requirements.

4.1a

Whole House Ventilation Requirement

Every new home must have a system consisting of fans, controls, and ducts or equivalent that provides fresh air for the dwelling unit. There are three compliance options for meeting the whole house balanced ventilation requirement:

1. ASHRAE 62.2-2019 (Ventilation and Acceptable Indoor Air Quality in Low-Rise Residential Buildings)
2. Passive House ventilation requirements (PHI or PHIUS)
3. Prescriptive method

Exceptions:

1. Whole house balanced ventilation systems that are controlled based on pollutant levels (e.g., carbon dioxide or volatile organic compounds) are not subject to the run-time ventilation rate minimums in the standards referenced above.
2. Tiny houses may install exhaust-only ventilation systems.

The whole house ventilation system must meet the flow requirement (cubic feet per minute, or CFM) for the home size (Section 4.1b); use fans that meet efficiency, durability, and noise requirements (Section 4.1c); and have automatic controls, that is, operate *without the need for anyone to turn it on or off* (Section 4.1d).

Types of balanced ventilation systems. Balanced ventilation systems use fans to both provide fresh air (from outdoors) and exhaust stale air. Supply and exhaust air are of equal capacity to achieve pressure equalization in the home. Heat recovery ventilators (HRVs) and energy recovery ventilators (ERVs) use heat exchangers to transfer energy from the outgoing (exhaust) air to the incoming (fresh) air without mixing the air streams. When correctly installed, balanced systems do not significantly affect the air pressure in the house and save money by recovering heat from exhaust air before dumping it outside, unlike exhaust-only systems.

A typical balanced ventilation system is depicted in Figure 4-1.

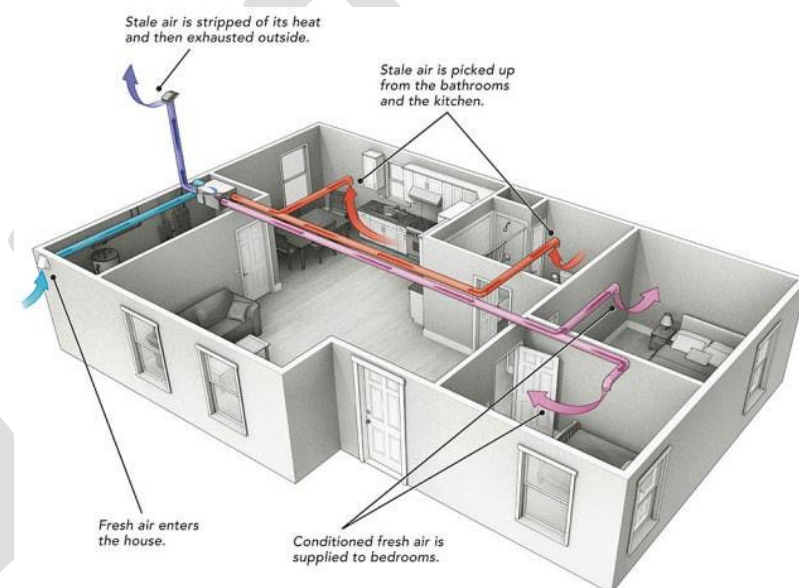


Figure 4-1. Balanced Ventilation System [Source: *Breathe Easy With Balanced Ventilation*, GreenBuildingAdvisor.com]

Equipment must be installed according to the manufacturer’s instructions. All ventilation systems must have a provision for circulating air to all finished living spaces, such as distribution ducts, grilles, transoms or door undercuts. If door undercuts are used, they must be at least 0.5 inch above the finished floor surface.

DRAFT

Whole House Flow Requirement

Depending on which of the four compliance options from Section 4.1a is chosen, the flow requirement varies. Flow rates can be tested on site using approved methods (e.g., a flow hood or a calibrated orifice combined with a digital manometer). **Note:** CFM = cubic feet per minute.

1. To get the required CFM using **ASHRAE 62.2-2019**, do a calculation that accounts for the home characteristics. The easiest way to determine the CFM is to use a free online calculator such as that offered by Residential Energy Dynamics (<http://www.residentialenergydynamics.com/REDCalcFree/Tools/ASHRAE6222016>).¹⁰ Note that to claim infiltration credit, actual blower door test result must be entered. Coordinate with your blower door air leakage tester to determine sizing requirements.
2. To get the required CFM using **Passive House Standards**, check with the particular standard you are using (PHIUS or PHI). Generally speaking, the supply air requirement is 18 CFM/person or 0.3 ACH; the extract air is 35 CFM per kitchen, 24 CFM per full bathroom, and 12 CFM per half bath or utility/storage room. The design CFM is the greater of the extract or supply requirement.

The advantage of these two methods is that they adjust the ventilation needs to the house and/or occupants. There is a prescriptive method of CFM calculation that is simpler but does not account for the characteristics of the house and/or occupants to the same level.

3. If not using the methods above, take the **Prescriptive** approach to determining CFM. If the installed ventilation system will be flow tested, it must provide a minimum of 15 CFM plus 15 CFM for each bedroom. For example, a 4-bedroom home would require $15 \text{ CFM} + (4 \times 15) \text{ CFM} = 75 \text{ CFM}$. If the ventilation system is not tested, capacity must meet or exceed the amount listed in Table 4-1 using fan flow ratings at 0.1 inches w.g. static pressure in accordance with HVI911.

Table 4 1. Rated Capacity Requirements for Untested Whole-House Ventilation Systems

| Number of Bedrooms | Minimum Rated Capacity (CFM) |
|-------------------------|-------------------------------------|
| 1 | 50 |
| 2 | 75 |
| 3 | 100 |
| 4 | 125 |
| 5 | 150 |
| Homes over 3000 sq. ft. | 0.05 x sq. ft. of conditioned space |

¹⁰ This tool will be moving to the Building America Solution Center website in mid to late 2024: <https://basc.pnnl.gov/>.

DRAFT

4.1c

Fan Durability Requirements

Fans installed as part of a whole-house ventilation system must be rated for “continuous duty” and have manufacturer flow ratings as listed in HVI 911

4.1d

Controls

The whole-house ventilation system must have an automatic control or be capable of being set remotely for continuous operation. That is, it runs without relying on a person to turn it on or off. Continuous operation or timed switches are examples of accepted strategies; twist or crank-style timers or switches controlled solely by a humidity sensor (humidistat, or de-humidistat) are not acceptable as controls for the whole-house system.

Continuously operated systems shall not have local controls that have the ability to turn the system off. However, these systems must have a remotely mounted (i.e., not in the living space) on/off switch provided it is appropriately labeled.

4.1e

Installation

All ventilation equipment (both whole-house and local) must be installed according to the manufacturer’s instructions and in accordance with the following requirements:

- Fan housings for ceiling- or wall-mounted fans must be air-sealed to the ceiling or wall opening.
- Inlet grilles for ducted systems must be air-sealed to the ceiling or wall.
- Smooth wall ducts (e.g. metal or composite) must be used for all duct runs longer than 8 feet. All ducts and distribution components shall be located within the building's thermal envelope.

- Mechanical fasteners — not just tape — must be used to connect the ducts to the fan.
- All joints, seams and connections must be mechanically fastened and sealed with welds, gaskets, o-rings, mastics (adhesives), mastic embedded fabric systems or approved tapes. **Note:** Standard “duct tape” is not allowed for sealing ducts since it dries out, becomes brittle and falls off.
- Remote (not in living space) whole house fans must be acoustically isolated from the structure/framing of the building and from attached hard ducts. This is generally done by using at least 1 foot, but no more than 2 feet, of insulated, flexible ducting. (This requirement does not apply to fans mounted in ceilings or walls.)
- Intake openings, if used, must be located a minimum of 10 feet from any hazardous or noxious contaminant, such as vents, chimneys, fuel fills, streets, alleys, parking lots and loading docks. The bottom of the intake opening(s) must be at least 1 foot above the expected snow accumulation level.
- Outside openings for both supply and exhaust must be protected with screens, louvers or grilles having a minimum opening size of ¼ inch and a maximum opening size of ½ inch.

4.1f

Local (Spot) Ventilation

Bathrooms, kitchens and laundry rooms are places where pollutants may be generated in high concentration. When these areas are being used, an exhaust fan directs pollutants directly to the outdoors before they can negatively impact air quality in the home.

All bathrooms containing a bathtub, shower, spa or similar bathing fixture must have an exhaust fan with a minimum tested capacity of 50 CFM for intermittent fans, or 20 CFM for continuously operated (24 hours per day) fans. If the whole-house ventilation system does not provide adequate local ventilation, a separate fan with the specified capacity must be installed.

4.1g

Clothes Dryers

All clothes dryers must be exhausted to outdoors according to the manufacturer’s instructions (except clothes dryers designed by the manufacturer to be unvented and to not contribute to the interior moisture load, such as condensing dryers and heat pump dryers). Dryer exhaust systems must be independent of all other systems and must transport the dryer exhaust all the way to the outdoors (not to the attic or other space).

4.1h

Makeup Air for Exhaust Hoods and Dryers

Mechanical exhaust hood systems and clothes dryers capable of exhausting in excess of 400 CFM must be provided with makeup air at a rate approximately equal to the exhaust air rate. The makeup air systems must also be equipped with a means of closure and be automatically controlled to start and operate simultaneously with the mechanical exhaust system.

4.1i

Dampers

Dampers with positive closures shall be installed to keep outside air from entering the exhaust duct when the system is not operating. **Exception:** Mechanical ventilation systems designed for continuous operation.

4.2

Combustion Safety

The Residential Energy Code requires the provision of combustion air to any natural draft combustion equipment or a sealed combustion system in order to reduce the likelihood of indoor air quality and venting problems. Specifically, it requires that air for combustion be provided for chimney-vented devices.

Additions, Alterations, Renovations and Repairs

Combustion safety requirements must be met when new heating or cooling equipment is installed in either an addition or equipment retrofit application. The combustion safety requirements in these scenarios are only associated with the new equipment unless whole-building alterations have been performed such that the entire building is considered *unusually tight construction*.

An existing building would be considered *unusually tight construction* when the whole building meets the RBES requirements air leakage requirements of 0.15 CFM50/Sq. Ft. of building shell area of all six sides of the building or the building fails a “worst-case depressurization test”. These air leakage levels are likely only associated with full building air sealing activities covering all components of the building shell. In this case, existing equipment would need to be brought into compliance with the RBES combustion safety requirements.

A “worst-case depressurization test” is used to determine whether combustion appliances in a building might spill into the home after any of the building changes above are undertaken. The worst-case depressurization test is conducted by creating the largest combustion appliance zone (CAZ) depressurization due to the combined effects of door position, exhaust appliance operation, and air handler fan operation. A base pressure must be measured with all fans off and doors open. The worst-case depressurization is the pressure difference between worst-case and the base

pressure.

4.2a

Oil and Gas Appliances

Unvented fuel-fired heaters, including room heaters and unvented fireplaces are prohibited.

RBES requires all new homes containing chimney-vented combustion devices to be provided with combustion and dilution air as required by the gas and oil codes (National Fire Protection Association [NFPA] Standard 54 [for gas] and Standard 31 [for oil].) Although these entire codes may not be in effect in certain areas of

DRAFT

Vermont, the requirements for combustion and dilution air have been incorporated into the Energy Code and therefore apply regardless of whether a locality has adopted the oil and gas codes.

The Energy Code specifically states that all new homes built in accordance with the RBES meet the definition of “unusually tight construction” as defined in the oil and gas codes. This means that combustion and dilution air may not be taken from the living space, and that the combustion and dilution air must be provided regardless of the volume of the space.

Additionally, in most cases, **RBES prohibits taking that air from garages, attics or crawl spaces.** Although NFPA 54 and 31 both allow combustion air to be taken from adjacent spaces, this is specifically prohibited in Vermont. In general, combustion and dilution air must be taken from outdoors.

Exception: If all the combustion devices in the home are either direct-vent appliances (also called sealed combustion; whereby all air for combustion is supplied directly from outdoors and all flue gases are discharged directly to outdoors) or mechanical draft appliances (where a fan is used to remove flue gases), or the home is all-electric, the combustion and dilution air requirements for oil and gas appliances do not apply.

4.2b

Solid-Fuel Appliances

All solid fuel-burning (i.e., wood, pellets and coal) appliances must have tight-fitting (defined as gasketed doors with compression closure or compression latch system) metal, glass or ceramic doors. **Note:** that many common glass bi-fold fireplace doors do not meet the requirements of RBES Code without modification. The only exception to this is a home certified to have passed the worst-case testing procedure outlined in RBES Appendix RA – Recommended Procedure for Worst-Case Testing of Atmospheric Venting Systems; the test must be done by an approved third party, with a written report of the results signed by that party.

Solid fuel-burning appliances must have ducted combustion air from outdoors. This exterior air intake:

- Cannot take air from within the garage, attic or basement.
- Cannot terminate to the exterior higher than the firebox nor have a vertical rise within 18 inches of the firebox.
- Where a woodstove or fireplace is installed below grade (e.g. in a basement), the combustion air intake on the home’s exterior may be located above the firebox if the combustion air supply point is below the firebox and the combustion air intake point is greater than 15 feet below the top of the chimney.
- Must deliver combustion air to the firebox. For older woodstoves and cookstoves where direct connection of combustion air is not possible, combustion air may be delivered within 24 inches of the stove’s air intake opening.
- Must be screened with ½ inch mesh.
- The air inlet shall be closable and designed to prevent debris from dropping into the air intake.
- Exterior air inlet shall be installed so as to remain free of obstruction from snow.

- Must be a minimum of 6 square inches and not more than 55 square inches. The passageway must be constructed of non-combustible, masonry or 30-gauge (or thicker) metal, with a minimum 1-inch clearance to combustibles for the length of the combustion air intake.

Factory-built fireplaces, masonry fireplaces and solid-fuel-burning appliances that list exterior air supply ducts as optional or required for proper installation are permitted to be installed with those exterior air supply ducts installed according to the manufacturer's installation instructions in lieu of the installation requirements listed above. *There is no exemption from the exterior air supply requirement. It is not permitted to use fresh air from a whole-house ventilation system to provide make-up air / fresh air for solid fuel appliances. The manufacturers of some factory-built fireplaces, masonry fireplaces and solid-fuel-burning appliances list exterior air supply ducts as optional, but in Vermont it is required.*

4.2c

Spillage Testing

All combustion equipment that is not power-vented or direct-vented (wherein combustion air is drawn directly from the outdoors), shall establish complete draft without spillage under "worst-case" conditions within two minutes. This requirement must be met in new homes and in existing homes after code applicable renovations, alterations or repairs to the building envelope, mechanical equipment, combustion vent system or ductwork.

Appendix RA – Recommended Procedure for Worst-Case Testing of Atmospheric Venting systems and the current Building Performance Institute (BPI) standard ANSI/BPI-1200 are recommended test procedures that may be used to meet this requirement.

Existing Homes: Additions, Alterations, and Repairs

Additions, alterations and repairs to existing homes, conducted after July 1, 2024, must comply with the requirements in Chapter 5. The following are circumstances where existing homes (or portions thereof) must comply with the Code.

- **Additions:** Any extension or increase in the conditioned space floor area or height of a building or structure.
- **Alterations:** Any construction, retrofit or renovation to an existing structure other than repair or addition. Also, a change in a building, electrical, gas, mechanical or plumbing system that involves an extension, addition or change to the arrangement, type or purpose of the original installation.
- **Repairs:** The reconstruction or renewal of any part of an existing building for the purpose of its maintenance or to correct damage.
- **Changes in Space Conditioning:** Any nonconditioned or low-energy space that is altered to become conditioned space.
- **Changes in Use:** Spaces undergoing a change in use that would result in an increase in demand for either fossil fuel or electrical energy.
- **Major renovations** to homes under an Act 250 permit that trigger an Act 250 permit amendment request would need to follow Stretch Code requirements after July 1, 2024.
- **Historic Buildings:** Construction, repair, alteration, restoration and movement of structures, and change of occupancy related to a historic building need to comply unless a “Historic Building Exemption Report” has been submitted to the State Historic Preservation Office (SHPO) and has been signed by the owner or registered design professional demonstrating that compliance with a particular provision would threaten, degrade or destroy the historic form, fabric or function of the building. The SHPO will review and validate the exemption request. A template for the report is available on both the SHPO and PSD websites.
- **Additions to an existing building,** building system or portion thereof shall conform to the provisions of this code as those provisions relate to new construction without requiring the unaltered portion of the existing building⁵ or building system to comply with this code.
- **An addition shall be deemed to comply** with this code where the addition alone complies, where the existing building and addition comply with this code as a single building, or where the building with the addition does not use more energy than the existing building.

Exceptions

The following building conditions do not have to comply with any of the Code requirements:

1. Unaltered portions of the existing building or building supply system.
2. Storm windows installed over existing fenestration.
3. Connections or repairs to, or maintenance of existing mechanical systems do not constitute an alteration to that system. Where ducts from an existing heating and cooling system are extended to an addition, duct systems with less than 40 linear feet in unconditioned spaces are not required to be tested.
4. Glass-only replacements in an existing sash and frame.
5. Existing ceiling, wall or floor cavities exposed during construction, provided that these cavities are filled with insulation.
6. Construction where the existing roof, wall or floor cavity is not exposed.
7. Reroofing projects where neither the sheathing nor the insulation is exposed. If either the sheathing or insulation is exposed, then the cavity needs to be filled with insulation; this does not require building the roof up. Roofs without insulation in the cavity and where the sheathing or insulation is exposed during reroofing must be insulated either above or below the sheathing.
8. Alterations that replace less than 10% of the permanent light fixtures in the space where the alteration is taking place, provided that such alterations do not increase the installed interior lighting power.
9. Alterations or repairs that replace only the bulb and ballast within the existing light fixtures in a space provided that the alteration does not increase the installed interior lighting power.
10. Historic Buildings: No provisions of this code relating to the construction, repair, alteration, restoration and movement of structures, and change of occupancy shall be mandatory for historic buildings if it is demonstrated that compliance with that provision would adversely affect the historic building. If an exemption is needed, a "Historic Building Exemption Report" must be submitted to the State Historic Preservation Office (SHPO).¹¹ The report must be signed by the owner or registered design professional and demonstrate that compliance with a particular provision would threaten, degrade or destroy the historic form, fabric or function of the building. The SHPO will review and validate the exemption request.

¹¹ The report form is available on both the SHPO and PSD websites: <https://accd.vermont.gov/historic-preservation/review-compliance> and https://publicservice.vermont.gov/energy_efficiency/rbes. For guidance on how to think intentionally when addressing energy efficiency for Vermont's historic buildings, please visit <https://accd.vermont.gov/historic-preservation/planning> or contact the SHPO at accd.projectreview@vermont.gov.

DRAFT

Section 5.2

Compliance

Portions of the building that are altered must be brought into full compliance with the code that relates to that portion of the building with above exceptions. An addition shall be deemed to comply with this code where the addition alone complies, where the existing building and addition comply with this code as a single building, or where the building with the addition does not use more energy than the existing building. Alterations and repairs shall be such that the existing building or structure is no less conforming to the provisions of this code than the existing building or structure was prior to the alteration.

Existing buildings undergoing additions, alterations, or repairs need not comply with the whole-building balanced mechanical ventilation requirement in cases where there are unaltered portions of the existing building. Whole building retrofits resulting in existing building air leakage levels of 0.15 CFM50/Sq. Ft. of building shell area of all six sides of the building would require the installation of a balanced mechanical ventilation system.

The ventilation system for an existing building that meets or exceeds this air leakage level must comply with the Whole House Ventilation Requirements in Chapter 4. One of the ventilation compliance options, ASHRAE 62.2 2019 (Ventilation and Acceptable Indoor Air Quality in Low-Rise Residential Buildings), allows for infiltration credits to determine existing home ventilation system requirements, including the use of exhaust-only systems in certain situations. A balanced mechanical ventilation system would not need to be installed when following ASHRAE 62.2 if it determines an exhaust-only system would be acceptable.

Compliance can be achieved through any of the compliance paths, which include the following approaches: Package-Plus-Points (see Chapter 6), REScheck™ software (see Chapter 7), or a Home Energy Rating System (HERS) rating (see Chapter 8). For renovations, remodeling, or additions, a Home Energy Rating can be used to demonstrate compliance by rating the entire building, including the new and remodeled portions. Rating the entire building requires including both the existing and new sections of the building, to meet either the maximum HERS of 60 for Base Code or 59 for Stretch Code using the software version listed in Chapter 8.

Section 5.3

Prescriptive Compliance for Additions

An addition shall be deemed to comply with the code where the addition alone complies, where the existing building and addition comply with this code as a single building, or where the building with the addition does not use more energy than the existing building prior to the addition as demonstrated by an overall weighted U-factor

New building envelope assemblies that are part of the addition shall comply with the full

requirements for new construction defined in Chapter 2, including the Specific Insulation Requirements, Fenestration Requirements, and Air Leakage requirements.

- Air leakage testing (see Appendix A) is not required for additions complying based on the attributes of the addition alone, for alterations, or for repairs. Additions complying where the existing building and addition comply with this code as a single building, or where the building with the addition does not use more energy than the existing building must be tested and verified as having an air leakage rate not exceeding 3.0 ACH50 or 0.23 CFM50/Sq. ft. of the six-sided building shell area.

The building thermal envelope shall comply with one of the Packages defined in Table 5-1 of Chapter 5 of the Handbook, and attain the required points needed based on addition size as called out in Table 4-1 below. The Points Options for Base Code Table (5-3 in the Handbook) is to be used for defining points for compliance with the Prescriptive Packages.

DRAFT

Table 5-1. Required points by addition size

| BUILDING/DWELLING SIZE | BASE CODE REQUIRED POINTS | STRETCH CODE REQUIRED POINTS |
|-----------------------------------|---------------------------|------------------------------|
| Alterations | 0 | 0 |
| Additions < 250 square feet | 0 | 0 |
| Additions 250 to 500 square feet | 1 | 2 |
| Addition 501 to 1,000 square feet | 2 | 3 |
| Addition > 1,000 square feet | 3 | 4 |

Section 5.4

U-Factor Alternative and UA Alternative Compliance for Additions

U-factor alternative. An assembly with a U-factor equal to or less than that specified in Table 5-2 (RBES Table R402.1.4) shall be permitted as an alternative to the R-values in Base Package Table 6-1 of the Handbook. The building must still comply with the Points Table for Additions (Table 5-1) based on the Points by Component Table (Table 6-3)

Table 5-2. Equivalent U-Factors

| EQUIVALENT U-FACTORS | | | | | | | | |
|-----------------------|--------------------|------------------|---------------------|---------------------------------|----------------|-------------------|---------------------------|---|
| Fenestration U-Factor | Sky-Light U-Factor | Ceiling U-Factor | Frame Wall U-Factor | Mass Wall U-Factor ^b | Floor U-Factor | Basement U-Factor | Crawl Space Wall U-Factor | Slab & Unheated D Slab U-Factor & Depth |
| 0.30 | 0.41 | 0.020 | 0.044 | 0.060 | 0.027 | 0.039 | 0.039 | 0.05, 4ft |

Where the existing building and addition comply with this code as a single building, the U-factor alternative or UA alternative compliance method shall be permitted, provided that:

- a. airtightness is less than or equal to 0.15 CFM50/Sq. Ft. of the six-sided building shell area (~2 ACH50) tested, and
- b. the ventilation system is: Balanced; with ECM fan(s) plus $\geq 70\%$ SRE.
 - Alternatively, Where the total building thermal envelope UA (the sum of U-factor times assembly area), is less than or equal to the total UA resulting from multiplying the U-factors in Table 5-1 by the same assembly area as in the proposed building, the building shall be considered to be in compliance, with the same caveats for points. Exception: Additions complying based on the attributes of the addition alone using the U-factor alternative compliance method are not required to comply with the airtightness limit (a) or the balanced ventilation system and heat recovery efficiency requirements (b) above.

DRAFT

The Prescriptive method is the easiest way to ensure compliance with the Residential Energy Code. This chapter reviews:

- ★ Homes eligible for the Prescriptive Method.
- ★ When and how to use the Prescriptive Method.

Chapter 6

The Package-Plus-Points Prescriptive Compliance Method for Base Code and Stretch Code

The Package-Plus-Points prescriptive method is a simple and flexible way to plan for and demonstrate compliance with the RBES Energy Code for both Base Code and Stretch Code. It requires you to build a home that meets:

1. The *Basic Requirements* (see Chapter 3);
2. The *Ventilation and Combustion Safety Requirements* (see Chapter 4);
3. The *Packages-Plus-Points Requirements* (see tables in this chapter).

If you do not use this compliance method, the other options are to use the **REScheck™ Software Compliance Method** (Chapter 7) for Base Code compliance or energy rating services via the **Home Energy Rating Compliance Method** (Chapter 8) for Base Code or Stretch Code.

Section 6.1

When to Use the Package-Plus-Points Method

The Packages-Plus-Points method is for homes whose thermal and heating efficiency values match or exceed those in the Packages Table for your house type AND attain the specified number of points based on your house type

and size. Refer to tables in this Chapter. Homes with metal framing for exterior walls cannot use this method.

If the values for your home do not meet the values specified in one of the Packages and/or you do not achieve/plan to achieve the number of points required, you must use a software or energy rating services compliance method. The two alternatives are the **REScheck™ Software Compliance Method** (Chapter 7) or the **Home Energy Rating Method** (Chapter 8).

Section 6.2

New for the 2024 RBES

The Package-Plus-Points approach introduced in 2020 has been streamlined and simplified in 2024.

- Base and Stretch Energy Codes now use the same Standard Package (but then require a different number of Points to comply).
- Instead of five Packages in 2020, the 2024 Energy Code now has just two Packages: a “Standard” Package and a “Log Home” Package.
- The options for achieving Points have expanded, including a significant number of Points available for installing heat pump technologies (for space conditioning and water heating), considering embodied energy in insulation materials, and other additions.
- There is a shift to “U-Factors” in the Standard Package to better describe “building assemblies” that comprise multiple layers of insulation and other building materials. This shift is in line with increasing emphasis on “continuous insulation” and other strategies to make our buildings more efficient. (See the new Chapter 2 Moisture Management for Durable Buildings for more on building assemblies and the sidebar describing the difference between “R-Values and U-Factors” below.)

R-Values and U-Factors

R-values measure a product’s resistance to heat flow while U-factors tell us the rate of heat transfer through a building assembly. The higher the R-value, the better at insulating. R-value typically refers to just the insulation's impact on heat transfer. On the other hand, U-factor measures the rate of heat transfer through an entire assembly of materials. Products or assemblies with a lower U-factor will be more energy efficient. R-values and U-factors are the inverse of each other. That is, $R = 1/U$ and $U = 1/R$. For example:

- R-20 batt in a 2x6 16” on-center wall = $R=17 = U=0.060$
- R-20 batt in a 2x6 16” on-center wall with R-5 continuous insulation = $R=23 = U=0.043$

There is a helpful free tool to determine building assembly U-factors available from Ekotrope at:

- <https://www.ekotrope.com/r-value-calculator>

Compressed Insulation

The reported R-values for most insulation products assume that the insulation has been installed per manufacturer specifications. For most insulation types, particularly batt insulation, this assumes the insulation has no compression. Insulation R-values and assembly U-factors must be de-rated to reflect any compression associated with the insulation installation.

Section 6.3

Meeting Base and Stretch Code Using the Package-Plus-Points Method

Buildings must meet the **Basic Requirements** (see inside front cover and Chapter 3) and **Ventilation and Combustion Safety Requirements** (see Chapter 4). Be prepared to identify nominal R-values and U-factors for the building components for your home using manufacturers' product information. If a single building component in your home has two or more different thermal values (i.g., R-38 ceiling and R-49 ceiling), calculate the average U-factor to determine compliance. Remember that lower U-factors are better. (See Appendix C if you need help.)

Then, take the following three steps during the design stage, whenever there are design changes, and upon construction completion, and steps 4 and 5, below upon completion of construction:

1. Ensure that you comply with the Standard Package (or Log Home Package if building a log home) listed in Table 6-1; and
2. Determine the number of points needed to comply with Table 6-2 based on building size; and
3. Incorporate a sufficient number of points from Table 6-3 to meet the points requirements from Table 6-2.

Note that the Log Homes package applies to homes with an assembly of individual structural logs for use as an exterior or interior load bearing wall, shear wall or non-load bearing wall. Insulation may be applied to the interior or exterior log surface to decrease wall U-factor when the weather side is constructed in compliance with ICC 400-2022.

The R-values for your home must be *equal to or greater than* the selected package. The U-factors for your home must be *equal to or less than* the selected package. All requirements in the footnotes of the Tables must be met.

If your home meets or exceeds the requirements for one of the predefined Packages AND meets the Points needed, you can proceed to step 4. **If your home does not meet the requirements** for one of the Packages or does not have enough Points, consider whether it is feasible to make a design change, or consider another compliance method (Chapters 7 and 8).

4. Obtain a **blower door air leakage test** from a certified tester. See Section 3.1b for details.
5. **Upon completion of construction, self-certify your compliance** with the Energy Code by filing a Vermont Residential Building Energy Standards (RBES) Certificate. The certificate is a statement that the home meets or exceeds the requirements of the Energy Code. The process:
 - a. Complete the certificate when the home is 100% finished and has met the blower door air leakage test. See Chapter 9 for detailed instructions on filing.
 - b. Within 30 days, send one copy each to:
 - The Town Clerk for the town or city in which the home is located. (**Note:** Check local procedures before filing the certificate; local fees and forms may be required.) and
 - *Vermont Public Service Department*
Efficiency and Energy Resources Division
112 State Street
Montpelier, VT 05620-2601

If the home is participating in a utility “new construction” program, check with the utility; you may need to provide a copy in order to receive an efficiency incentive or rebate. Be sure to keep one copy for your records as well.

6. **Post the original certificate in the home**, affixing it on or near the electrical service panel or heating equipment.

When to Evaluate Using the Prescriptive Method

To ensure Code compliance, compare the proposed design with the required Package-Plus-Points:

1. During the design stage.
2. Whenever there are design changes.
3. Upon completion.



Prescriptive Tables begin on the next page.

For Base or Stretch Code, start by ensuring compliance with the following components in Table 6-1.

Table 6-1. Requirements by component for Base and Stretch Code

| Component ^f | Package 1 | Package 2 |
|---|---|---|
| | “Standard Package” | “Log Homes” |
| Ceiling – flat attic ^g | U-0.020: R-49 ^g | |
| Ceiling – slope (no attic) | U-0.025: R-44 | |
| Above Grade Wall ^b | U-0.044: Examples: R-20+5ci ^e R-13+10-ci R-20 (6 ½” ci (SIP) or other) | Construct log home walls to ICC 400—2022 Standard on the Design and Construction of Log Structures Table 305.3.1.2 or Vermont RBES Table R402.1.6 |
| Frame Floor | U-0.029: R-38 | |
| Basement/Crawl Space Walls ^c | R-20ci OR R13+10ci | |
| Slab, on grade ^d | R-20,4’ (edge) OR R-15,4’(edge) + R-7.5 (under entire slab) | |
| Slab, on grade, Heated ^d | R-20,4’ (edge) + R-15 (under entire slab) | |
| Windows | U-0.30 | |
| Skylights | U-0.41 | |
| Doors | U-0.37 | |
| Air Leakage | ≤0.15 CFM50/Sq. Ft. of Building Shell (~2 ACH50) ^h | |
| Ducts | Inside thermal boundary | |
| High Efficacy Light Sources | 100% | |

For SI: 1 foot = 304.8 mm.

- R-values are minimums. U-factors are maximums. Where insulation is installed in a cavity that is less than the label or design thickness of the insulation, the installed R-value of the insulation shall be not less than the R-value specified in the table. See Section R402.1.4 for alternative compliance methods.
- These are *example* wall assemblies. Any wall assembly would need to meet required U values and should consider building science to avoid moisture concerns. See Chapter 2 for building science guidance and more example wall assemblies.
- The continuous portion of basement and crawlspace insulation can be met through interior, exterior or combination.
- “4 ft” can be horizontal or vertical coverage including slab edge. “Edge and under” requires complete coverage. Up to 8 lineal feet of exposed slab edge may be insulated to R-10. “Heated slab” are those with embedded radiation.
- The first value is cavity insulation, the second value is continuous insulation, or “ci”, so “20 + 5ci” means R-20 cavity insulation plus R-5 continuous insulation.
- Consider building science principles in all design and construction. Buildings should be designed and constructed recognizing principles

- behind moisture vapor control approaches for cold climates.
- g. If there is insufficient space in the eaves, installing R-38 over the top of exterior walls shall be deemed to satisfy the requirement for R-49 insulation provided the rest of the ceiling is R-49. (See Section R402.2.1). Multifamily buildings using continuous insulation with a maximum U-factor of 0.023 or tapered insulation with an average U-factor of 0.023 for the ceiling assembly satisfies this requirement. A minimum value of R-12 is required for tapered insulation.
 - h. CFM50/Sq. Ft. of building shell is the building leakage measured at 50 pascals of pressure divided by the surface area of the building. Compliance with the air leakage limit must be shown in CFM50/Sq. Ft. The ACH50 equivalence is shown for reference only.
 - i. Installing R-38 over the top of exterior walls where insulation is compressed in the eaves shall be deemed to satisfy the requirement for R-44 where there is insufficient space in framing rafters for more than R-38 provided the rest of the ceiling is R-44. See R402.2.2 for more detail.

All projects using the Package Plus Points compliance path must earn points in addition to meeting the requirements in Table 6-1. Determine the number of points required based on Table 6-2. The required points vary based on the applicable code, Base or Stretch, and the size of the building.

Table 6-2. Required points by building size for Base and Stretch Code

| BUILDING/DWELLING SIZE | BASE CODE REQUIRED POINTS | STRETCH CODE REQUIRED POINTS |
|---|----------------------------------|-------------------------------------|
| Alterations | 0 | 0 |
| Additions < 250 square feet | 0 | 0 |
| Additions 250 to 500 square feet | 1 | 2 |
| Addition 501 to 1,000 square feet | 2 | 3 |
| Addition > 1,000 square feet | 3 | 4 |
| Multifamily <650 square feet | 0 | 1 |
| Multifamily 650 to 900 square feet | 1 | 2 |
| Multifamily 900 to 1,250 square feet | 2 | 3 |
| Multifamily >1,250 to 2,500 square feet | 4 | 5 |
| < 2,500 square feet | 5 | 7 |
| 2,500 to 4,000 square feet | 7 | 12 |
| > 4,000 square feet | 10 | 15 |

Building size for the above points table is determined by the conditioned floor area per dwelling unit within the building thermal envelope, including unfinished basements and storage/utility spaces. The Multifamily square feet point requirements cannot be used for semidetached (semi attached, side-by-side), row houses and townhouses, defined as single family dwellings in Definitions Appendix F. Multifamily dwelling unit size is based on the average dwelling size for the building.

Table 6-3 details the number of points associated with various component upgrades. Use the list from Table 6-3 to determine which additional building improvements can be used to meet the overall points required by Table 6-2 above.

Table 6-3. Points options for Base and Stretch Code, by component

| Component | | Description | Points | |
|------------------------|--|---|---|---|
| Envelope | Slab (on or below grade, heated or unheated) | R-20 around perimeter and below entire slab OR^b | 2 | |
| | | R-25 around perimeter and below entire slab | 3 | |
| | Walls | R-28 2x6 cavity insulation with continuous (R20+9ci or similar) (U-0.036 wall assembly) OR^b | 1 | |
| | | Walls | R-35 double stud or similar (cavity and continuous) (U-0.028 wall assembly) OR^b | 2 |
| | | | R-40 double stud or similar (cavity and continuous) (U-0.025 wall assembly) OR^b | 3 |
| | | R-48 SIP 10 1/4" XPS or similar (cavity and continuous) (U-0.021 wall assembly) | 4 | |
| | Ceiling | R-60 attic flats (U-0.018) and R-49 slopes, vaulted and cathedral (U-.020) | 1 | |
| | | R-80 attic flats (U-0.013) and R-60 slopes, vaulted and cathedral (U-.018) | 2 | |
| | Floors - Exposed | R-49 (U-0.021) | 1 | |
| | Windows | Average U-factor ≤ 0.27 OR^b | 1 | |
| | | Average U-factor ≤ 0.25 OR^b | 2 | |
| | | Average U-factor ≤ 0.21 OR^b | 3 | |
| | | Average U-factor ≤ 0.18 | 4 | |
| | Doors - Exterior | U-0.26 | 1 | |
| Air Leakage | Tight | Tested to ≤ 0.11 CFM50/Sq. Ft. of Building Shell (6-sided) (~ 1.5 ACH50) OR^b | 1 | |
| | Tighter | Tested to ≤ 0.07 CFM50/Sq. Ft. of Building Shell (6-sided) (~ 1.0 ACH50) OR^b | 2 | |
| | Tightest | Tested to ≤ 0.03 CFM50/Sq. Ft. of Building Shell (6-sided) (~ 0.5 ACH50) | 3 | |
| Mechanical Ventilation | Better Heat Recovery OR | Balanced ventilation with ECM fans and $\geq 80\%$ SRE and ≥ 1.2 cfm/watt OR^b | 3 | |
| | Better Electrical Efficiency | Balanced ventilation with ECM fans and $\geq 70\%$ SRE, and ≥ 2.0 cfm/watt | | |
| | Mechanical Ventilation Testing | Mechanical ventilation systems shall be tested and verified to provide the minimum ventilation flow rates required by Section R403.6. Testing shall be performed according to the ventilation equipment manufacturer's instructions, or by using a flow hood or box, flow grid, or other airflow measuring device at the mechanical ventilation fan's inlet | 1 | |

| | | | |
|----------------------------------|--|---|----|
| | | terminals or grilles, outlet terminals or grilles, or in the connected ventilation ducts. | |
| Heating and Cooling ^a | Basic Equipment | ENERGY STAR basic: (1) Gas/propane furnace ≥ 95 AFUE, Oil furnace ≥ 85 AFUE; (2) Gas/propane boiler ≥ 90 AFUE, Oil boiler ≥ 87 AFUE; OR^b | 1 |
| | Cold Climate Air Source Heat Pump | Whole building heating /cooling is ENERGY STAR v.6 labeled ^d | 5 |
| | Ground Source Heat Pump | Whole building heating /cooling is Ground Source Heat Pump (GSHP) and ENERGY STAR labeled ^d | 10 |
| | Air-to-Water Heat Pump | Whole building heating/cooling is Air-to-Water Heat Pump (ATWHP) COP ≥ 2.5 | 5 |
| | Advanced Wood Heating System | Whole building heating/cooling is Advanced wood heating system from http://www.rerc-vt.org/advanced-wood-heating-system/eligible-equipment-inventory-eei | 5 |
| | Low-Temperature Hydronic Distribution System | Hydronic distribution system designed to meet building peak heating demand with maximum 120-degree water | 1 |
| | Demand Responsive Thermostats | All electric heating thermostats provided with <i>demand responsive controls</i> | 1 |
| Water | Heat Pump Basic | Electric Heat Pump Water Heater UEF ≥ 2.20 OR^b | 3 |
| | Heat Pump Advanced | Electric Heat Pump Water Heater UEF ≥ 3.30 | 5 |
| | Low flow | All showerheads ≤ 1.75 gpm, all lavatory faucets ≤ 1.0 gpm, and all toilets ≤ 1.28 gpf ^c OR^b | 1 |
| | Certified ^e | Certified water efficient design per WERS, WaterSense, or RESNET HERS _{H2O} | 2 |
| | Drain heat recovery | Drain water heat recovery system on <i>primary showers</i> and tubs | 1 |
| | Recirculation User-demand | Controlled hot water recirculation system with user-demand via push-button for furthest fixtures | 1 |
| | Pipe Insulation | All service hot water piping is insulated to at least R-5 from the hot water source to the fixture shutoff. | 1 |
| | Demand Responsive Controls | Electric storage water heater(s) provided with <i>demand responsive controls</i> | 1 |

| | | | |
|--------------------------------------|---|--|----------------------|
| | Point of Use Electric Water Heater | Remote fixtures requiring hot water supplied from a localized source of hot water with no recirculating system. | 1 |
| | Solar Ready Zone | Follow R402.7 Solar –ready zone requirements. These points are only available for Base Code and not Stretch Code since Stretch Code requires following R402.7. | 2 |
| | Solar Hot Water | Solar hot water system designed to meet at least 50% of the annual hot water load | 2 |
| Renewables | On-Site Generation | Solar photovoltaic (PV) (or other on-site renewable energy system), 1 point per 1.5 kW per housing unit of renewable generation on site | 1 per 1.5 kW, max. 4 |
| Other Measures | Monitoring | Whole-building energy monitoring system installed, minimum 5 circuits and homeowner access to data | 1 |
| | <u>Radon Mitigation System</u> | <u>Radon mitigation following EPA Standards of Practice</u> is installed and documented to homeowner | 1 |
| | <u>Energy Model</u> | <u>Building energy model with projected annual energy use and costs developed, used in design and construction decisions, and provided to homeowner</u> | 1 |
| | Battery | Minimum 6 kWh grid-connected dispatchable demand-response-enabled battery | 1 |
| | Advanced Lighting Controls | All lighting for at least 50% of floor area is controlled and/or continuously dimmed based by occupancy, daylight, load shedding, and/or schedule. | 2 |
| Insulation Embodied Carbon Emissions | Global Warming Potential (GWP)/square footage (kg CO ₂ e/ft ²) | <u>Report the global warming potential (GWP) impact of project insulation materials as described in Section R408. Use calculation table R408.1.1 to summarize insulation GWP intensity (kg CO₂e/ft²) for the project. Default global warming potential (GWP) values for common insulation products are provided in table R408.1.2. The calculation may utilize Type III, product-specific environmental product declaration (EPD) in lieu of default values for insulation products. If EPD values are used for a given insulation product, include the sum of lifecycle stages A1-A3 from the sourced EPD instead of default GWP value when completing the calculation. Include A5 and B1 GWP values for SPF and XPS products, as noted in R408. OR^b</u> | 1 |
| | Global Warming Potential (GWP)/square | <u>Demonstrate a calculated insulation GWP intensity (kg CO₂e/ft²) less than 0.5. Product-specific EPDs may be used in place of default</u> | 2 |

| | | | |
|-----------------------|---|--|---|
| | footage (kg CO ₂ e/ft ²) | values, subject to requirements in R408. OR^b | |
| | | Demonstrate a calculated insulation GWP intensity (kg CO ₂ e/ft ²) less than 0. Product-specific EPDs may be used in place of default values, subject to requirements in R408. | 3 |
| Multifamily Buildings | Efficient Elevator Equipment | Elevators in the building qualify with Energy Efficiency Class A per ISO 25745-2, Table 7. | 1 |
| | Residential Kitchen Equipment | All dishwashers, refrigerators, and freezers comply with the most recent ENERGY STAR Most Efficient label. | 2 |
| | Water Heating System Submeters | Each individual dwelling unit served by a central service water-heating system is provided with a service hot water meter connected to a reporting system that provides individual dwelling unit reporting of actual domestic hot water use. | 1 |

Notes:

- For SI: 1 foot = 304.8 mm., a. Heating and cooling system points are only available if all components of primary systems comply.
- b. "OR" indicates that points are not additive; one component OR the following one can be selected, but not both.
- c. Applies to new construction only.
- d. https://www.energystar.gov/products/spec/central_air_conditioner_and_air_source_heat_pump_specification_version_6_0_pd
- e. Certification standard as of 1/1/2019 or later. "WERS" = Water Efficiency Rating Score <http://www.wers.us/>.
 EPA WaterSense compliance for all water products: <https://www.epa.gov/watersense>.
 RESNET Water Energy Rating Index compliant: http://www.resnet.us/professional/about/resnet_to_develop_water_efficiency_rating_system.

Cavity-Only Exemption

While not recommended, the 2024 RBES allows for an exemption from meeting the U-factor for walls listed in Table 6-1 (U-0.044). Building cavity-only 2x6 walls may be insulated to the manufacturer’s installation standards with at least R-20 insulation without additional continuous or other insulation. To make up for the lower performance of these walls, you must **achieve five (5) Points in addition to the Points required** from Table 6-2 above. See Appendix D for examples of ways to meet the higher points requirement associated with cavity-only wall insulation.

Alternatively, the REScheck (Chapter 7) or Home Energy Rating (Chapter 8) approaches could also be used to comply with 2x6 cavity-only walls.

Section 6.4

Tiny House Standards

"Tiny House" energy standards were added to the Energy Code for 2024. The definition of a Tiny House is "a detached dwelling unit of less than 400 square feet of floor area excluding lofts." Because Tiny Houses use less energy than larger houses, the energy standards are less stringent. Tiny Houses must comply with the envelope, insulation, and fenestration requirements below. All other code provisions are still required except that the mechanical ventilation system for Tiny Houses is not required to be a balanced ventilation system and may be exhaust-only.

- Ceiling flat attic U-0.033 (R-30);
- Ceiling slope U-0.04 (R-24);
- Above grade walls U-0.08 (R-13);
- Frame floors U-0.05 (R-21);
- Basement/crawl space walls R-20 continuous (ci) or R13+10ci;
- Slab on grade R-20 for 4' on edge or under, OR R-15,4'(edge) + R-15 (under entire slab);
- Heated slab on grade R-20,4' (edge) + R-15 (under entire slab);
- Windows U-0.30;
- Doors U-0.37;
- Air leakage 0.15 CFM50/Sq. Ft. of Building Shell (~2 ACH50);
- Ducts inside thermal boundary.
- Compliance with all other provisions of this code is required.

DRAFT

This chapter explains:

- ★ How the Rescheck Software Method works.
- ★ The advantages of this method.
- ★ System requirements.
- ★ How to obtain the software.

Chapter 7

.....

The REScheck™ Software Compliance Method

The *REScheck*™ Software Compliance Method involves the use of *REScheck*™ software to determine a home's compliance with the Residential Energy Code. This customized approach accommodates varied building techniques – including 24" stud spacing, stress-skin panels and metal framing – and offers flexibility in meeting the Code's Requirements. For this Method, you build a home that meets:

1. **The Basic Requirements** (see Chapter 3);
2. The **Ventilation and Combustion Safety Requirements** (see Chapter 4);
3. Using *REScheck*™ software, enter data on the home's thermal and efficiency values. The program determines if the home "passes."

If you do not use this compliance method, the other options are to use **the Packages-Plus-Points Compliance Method** (Chapter 65) or energy rating services via the **Home Energy Rating Compliance Method** (Chapter 87).

Important note: *REScheck*™ cannot be used to demonstrate Stretch Code compliance.

System

Requirements

The current version of REScheck software requires Windows 2010 or later. Mac users will need to use REScheck-Web

How the REScheck Software Method Works

Using *REScheck*[™] software, you simply specify component types (for example, 16" o.c. wood-frame walls), their area and their R-values or U-factors. There is no need to calculate average R-values and U-factors; you just enter the value of each component separately, along with its square footage, and the software performs the calculations.

Unlike the Packages-Plus-Points method, there are no “exempt” door or window areas; you enter data on each part of the thermal envelope, including all access hatches. The software performs all the calculations and determines if your home complies with the Residential Energy Code.

REScheck[™] enables you to quickly compare different insulation levels in different parts of your building to arrive at a package that works best for you, providing that you take care to (a) ensure the building will meet $ACH50 \leq 2.0$ and (b) install a balanced mechanical ventilation system that meets the heat or energy recovery efficiency required.

Section 7.2

Using REScheck[™] Software

At the design stage, whenever the design changes during construction, and again upon completion of construction for verification, complete steps 1 through 7. Upon completion of construction, complete steps 8 and 9:

1. **Review the Basic Requirements** summarized on the inside front cover (or refer to Chapter 3 for detailed explanations). Your project must meet all Basic Requirements.
2. **Follow the Ventilation and Combustion Safety Requirements.** (See Chapter 4)
3. Ensure that you meet two key construction requirements for using *REScheck*[™]:
 - a. At completion, the building meets the **air leakage requirement** for *REScheck*[™] compliance of ≤ 0.15 CFM50/Sq. Ft. of Building Shell (~2 ACH50) tested.
 - b. Install a **balanced ventilation system** with a minimum $\geq 70\%$ system recovery efficiency (“SRE”) and 1.2 cfm/Watt.
4. **Calculate the square footage of the building components** (windows, walls, ceilings, etc.). If you have components with different insulation values (for example, two flat ceilings with different R-values), calculate the square feet of each one separately. All parts of the thermal envelope must be included. Refer to the software manual or help function for details.
5. **Enter the basic project information** using *REScheck*[™] software. Enter building component data, choosing from the available descriptions and keying in areas (square footage), R-values and U-factors. See Section 5.5, Total UA Alternative and Table 5-2. See the software manual or help function for complete instructions.

6. The software continuously displays “passes” or “fails.” **If your building does not pass at first, make changes in building components until it does.** (For example, to determine whether more efficient windows will bring the home into compliance, simply change the window U-factor; the result displays almost instantaneously.) Contact the Energy Code Assistance Center at 855-887-0673 for any assistance you may need. If construction is complete and it does not pass, consider whether it is feasible to use another compliance method.

7. **After construction, obtain a blower door air leakage test** from a certified air leakage tester to verify compliance with the air leakage requirement for *REScheck*[™] compliance of ≤ 0.15 CFM50/Sq. Ft. of Building Shell (~ 2 ACH50)^h tested.

8. **Upon completion of construction, self-certify your compliance** with the Energy Code by filing a Vermont Residential Building Energy Standards Certificate. The Certificate is your documentation that the home meets or exceeds the requirements of the Residential Energy Code. The process:
 - a. Complete the certificate when the home is 100% finished. (See Chapter 9 for detailed instructions.)

 - b. Within 30 days, send one copy each to:
 - The Town Clerk for the town or city in which the home is located. (Note: Check local procedures before filing the certificate; local fees and forms may be required.)

 - The Vermont Public Service Department
Efficiency and Energy Resources Division
112 State Street
Montpelier, VT 05620-2601

If the home is participating in a utility “new construction” program, check with the utility. You may need to provide a copy in order to receive an efficiency incentive or rebate. Be sure to keep one copy for your records as well.

9. **Post the original certificate in the home**, affixing the label on or near the electrical service panel or heating equipment.

Section 7.3

How to Obtain REScheck[™] Software

The *REScheck*[™] software can be accessed at: <https://www.energycodes.gov/REScheck>

This chapter explains:

- ★ How home energy ratings can be used to demonstrate Code compliance.
- ★ The advantages of the Home Energy Rating method of compliance.

Chapter 8

The Home Energy Rating Compliance Method

Section 8.1

How the Home Energy Rating Method Works

The Home Energy Rating method is a “professional services” compliance method that a builder may utilize in order to demonstrate compliance with the Code.

This method is fundamentally different from the other two compliance methods (Packages-Plus-Points and *REScheck*[™] software) because it requires sophisticated energy modeling tools to demonstrate that a new home meets or exceeds the technical requirement of the Energy Code. It utilizes a home energy rating, which is an independent, detailed analysis of the home’s energy efficiency. This method also can model complex buildings or buildings with unusual features, such as a high glazing percentage.

In order to comply with the Residential Energy Code using this method, a home must meet all of the Basic Requirements for Home Energy Ratings (Table 7-1), the Ventilation & Combustion Safety Requirements and meet the specific Home Energy Rating target scores listed later in this chapter.

Home Energy Ratings offer the added benefit of having a professional review your project.

If you do not use this compliance method, the other options are to use the **Packages-Plus-Points Compliance Method** (Chapter 6) or the ***REScheck*[™] Compliance Method** (Chapter 7).

For this method, you must build a home that meets:

- The **Basic Requirements** (see Chapter 3);
- The **Ventilation and Combustion Safety Requirements** (see Chapter 4); and
- Achieve an energy rating of less than or equal to 60 for Base Code or 59 for Stretch Code (see Table 8-2 below).
- For Stretch Code, the requirements in Appendix A.

Section 8.2

Advantages of the Home Energy Rating Method

- **Less math and forms:** A professional energy specialist performs the calculations and fills out the Vermont Residential Building Energy Standards Certificate. [Note: the builder must sign and file the certificate]
- **Ventilation System and Blower Door Air Leakage Testing:** A professional energy specialist may test performance to determine compliance with the Energy Code ventilation and Blower Door Air Leakage Testing requirements. **Credit for airtightness and solar gain:** Other compliance methods do not allow builders to “earn credit” for building a house tighter than the maximum ACH50. Because the rating process includes the actual air tightness value, the energy rating can give credit for incremental improvements in air sealing. Likewise, solar gain is factored into the building model, so buildings with significant solar gain can take credit for being partially heated by the sun.
- **Credit for efficient domestic hot water (DHW) systems, including solar-heated systems:** The other compliance methods assume minimum efficiency for DHW. Energy ratings can account for increased DHW efficiency.
- **Credit for efficient heating, cooling and ventilation systems.**
- **Credit for electrically efficient lighting and appliances:** Your contractor should be able to provide up-to-date energy ratings for appliances and lighting, which can be incorporated into the design to help ensure the home’s compliance with the Energy Code.

Section 8.3

The Home Energy Rating

A home energy rating is a standard measure of a home's energy efficiency. In order to be used for Energy Code compliance, home energy ratings must be performed by a Vermont state-accredited rating organization. A certified Home Energy Rater does a detailed assessment of your home, which gets compared against a "reference home" – a model home of the exact size and shape as the actual home - so that your score is always relative to homes of the same size, shape and type. The result of the energy model is the Home Energy Rating Score (HERS) "index" that tells how energy efficient the home is, like a home's MPG (miles-per-gallon) rating. The lower the score, the more energy efficient the home (a net zero home gets a score of 0).

A signature is still required on Vermont Residential Building Energy Standards certificate for homes meeting the RBES performance requirements **through the Energy Rating Compliance method.**

Section 8.4

Minimum Thermal Envelope Efficiency Levels for HERS Compliance

While the HERS Rating method of compliance allows for trade-offs among building thermal envelope efficiency levels, there are minimum levels below which envelope efficiency levels may not be traded off. Table 8-1 lists the minimum thermal envelope efficiency levels for compliance through the Home Energy Rating method.

DRAFT

Table 8-1 Minimum thermal envelope efficiency levels for HERS compliance

| Mandatory Requirements | |
|---|--|
| Minimum Thermal Envelope Efficiency Levels for HERS Compliance | |
| <i>Component</i> | <i>Requirement^a</i> |
| Air Leakage | 0.15 CFM50/Sq. Ft. of six sided building shell area |
| Slab insulation | Unheated: R-10, 4 ft; Heated: R-15, 4 ft |
| Basement/Foundation Walls | R-15 continuous / R-19 cavity |
| Floors | R-30 (or insulation sufficient to fill the cavity, R-19 minimum) |
| Windows/Skylights | U-0.35 / U-0.60 |
| Above Grade Framed Walls | R-20 cavity or R-13 cavity + R-5 continuous |
| Ceilings | R-49 |

Table 8-2 shows the maximum HERS scores allowed for compliance with the Base and Stretch Codes for all residential structures, including log homes.

Table 8-2 Maximum HERS scores for Base and Stretch Codes

| | Maximum HERS Energy Rating Index[†] | Note |
|--------------|---|--|
| Base Code | 60 | A maximum of 5 of these points may be achieved with renewables |
| Stretch Code | 59 | A maximum of 5 of these points may be achieved with renewables |

[†]Based on REM/Rate version 16.3.3 or later or Ekotrope version 4.0 or later that is accredited by RESNET.

HERS Compliance Process

Home Energy Rating services can be used to verify Code compliance of a completed home. The recommended procedure is to follow these steps:

1. **Plan Review:** Submit plans and specifications to the HERS rater. If the home is not on track to meet the Energy Code as designed, the HERS rater recommends changes that will ensure compliance.
2. **Design Changes:** In the event that changes are made to the thermal and mechanical efficiency features, modifications can be analyzed to determine whether the new design complies with the Energy Code.
3. **Final Inspection:** When the home is complete, the HERS rater conducts a final inspection, including a blower-door test to evaluate the home's airtightness. A final energy model is created, resulting in a HERS score. Final documentation is provided showing whether the home meets the Energy Efficiency criteria of the Energy Code.
4. **Upon completion of construction, self-certify your compliance** with the Residential Energy Code by filing a *Vermont Residential Building Energy Standards Certificate*. The Certificate is your documentation that the home meets or exceeds the requirements of the Energy Code. The process:
 - a. Complete the certificate when the home is *100% finished*. (See Chapter 8 for detailed instructions.)
 - b. Within 30 days, send one copy each to:
 - *The town clerk* for the town or city in which the home is located. (Note: Check local procedures before filing the certificate; local fees and forms may be required.)
 - *The Vermont Public Service Department*
Efficiency and Energy Resources Division
112 State Street
Montpelier, VT 05620-2601
5. **Post the original certificate in the home**, affixing the label on or near the electrical service panel or heating equipment.

Chapter 9

Certification

The Vermont Residential Energy Code is one of the few codes in the country where the builder self-certifies that the home complies with the law. Builders are responsible for understanding the Energy Code, for building to the minimum (or better) standards, and for completing and filing a certificate.

Section 9.1

Types of Certification

Certification is accomplished by verifying the thermal and efficiency features of the home in the as-built condition. These features are recorded on one of two documents, depending on the situation:

1. If the home meets the technical requirement of the Residential Energy Code, a *Vermont Residential Building Energy Standards Certificate* (Figure 9-1) must be completed, filed and posted in the home.
2. If the home qualifies for the Owner/Builder Special Provision (see Section 1.4), a *Vermont Owner/Builder Disclosure Statement* (Figure 9-2) must be completed, filed and disclosed to prospective buyers. Homes covered under this provision do not have to meet the technical requirement of the Code, but documentation must be provided to the buyer prior to a purchase and sales agreement when the home is sold.

Section 9.2

The ‘Vermont Residential Building Energy Standards Certificate’

A *Vermont Residential Building Energy Standards Certificate* must be filed for each home covered by the Residential Energy Code. The certificate documents compliance with the Energy Code and represents a statement that the information it contains is accurate. The certificates must be printed and posted on or near the electric-service panel or heating equipment. After the certificate is filled out, you need to produce the necessary copies for filings and for your records. It is permissible to photocopy an original certificate and post the copy on or near the electrical panel or heating equipment in the home. Please note that the certificate has been updated since the 2020 RBES and is now a two-page document.

Note: Read the instructions in their entirety before completing the Vermont RBES Certificate.

For additions, alterations, renovations and repairs to existing homes, include a brief description of the project under the Existing Home Project Description section of the form and fill out the portions of the form pertaining to your project. For Owner/Builder projects, the Owner/Builder form should be completed (see Figure 9-2).

Fig. 9. 1: Example of the Vermont Residential Building Energy Standards Certificate

2024 Vermont Residential Building Energy Standards (RBES) Certificate (Pg 1)

This certificate is for projects started on or after July 1, 2024.

Before completing this form, refer to the instructions in Chapter 9 of the Residential Energy Code Handbook (6th edition).

For additions, alterations, renovations or repairs, only fill out applicable portions of certificate.

Property Address (Street, City, ZIP Code) _____

Construction START Date _____

Construction FINISH Date _____

Act 250 (Y/N) _____

Act 250 Permit # _____

Units _____

Stories _____

Conditioned Sq. Ft. _____

Bedrooms _____

Foundation: Basement Slab On Grade Crawl Space Other: _____

Applicable Code: Base Stretch

Project Description

Single family Renovation / alteration*

Multi-family Addition*

*Existing Home Project Description: _____

I certify to _____ (Owner) that the above information is correct and that the premises listed have been constructed in accordance with the Vermont Residential Building Standards (RBES) created under 30 V.S.A. § 51.

Date: _____

Signature: _____ Printed Name: _____

Company: _____ Phone: _____

30 V.S.A. § 51 requires this certificate label to be permanently affixed to the inside electrical service panel or heating or cooling equipment or nearby in a visible location. Copies of the certificate (and Home Energy Rating Certificate if Option 3 is used) also must be provided to 1) the Dept. of Public Service, 112 State St., Montpelier, VT 05602, and 2) the town clerk of the town where the property is located.

NOTE: Noncompliance with RBES may result in action for damages under 30 V.S.A. § 51. This label does not specify all 2024 RBES requirements. **QUESTIONS? CALL the Energy Code Assistance Center at 855-887-0673 or the VT PUBLIC SERVICE DEPARTMENT at 802-828-2811.**

Town clerk recording stamp

SPAN # _____

2024 Vermont Residential Building Energy Standards (RBES) Certificate (Pg 2)

Compliance Method:
MUST select Option 1,
Option 2, or Option 3

Option 1: Package-Plus-Points

BASE / STRETCH (circle one)
Package # _____
Points required: _____
Points achieved: _____
(Base requires up to 10pts/ Stretch up to
15pts, see Handbook Tables 5-2 and 5-5)
Ref. RBES for full reqs. of each point option

Option 2: REScheck software (cannot
be used for Stretch Code) Passes
_____ UA result _____ Max. UA

Option 3: HERS/ERI

_____ HERS Result (Overall)
_____ HERS without Renewables
_____ HERS software used, version #
(BOX) IAF incorporated into model
Approved rater name: _____
(Maximum HERS 60 Base, 59 Stretch)

- Envelope: Slab, R-20 around perimeter and below entire slab (2 pts)
- Envelope: Walls-R-28 2x6 cavity insulation with continuous (1 pt)
- Envelope: Walls- R-35 double stud or similar (cavity and continuous) (2 pts)
- Envelope: Walls- R-40 double stud or similar (cavity and continuous) (3 pts)
- Envelope: R-48 SIP 10 1/4" XPS or similar (cavity and continuous) (4 pts)
- Envelope: Ceiling, R-60 flat / 49 sloped (1 pt)
- Envelope: Ceiling, R-80 flat / 60 sloped (2 pts)
- Envelope: Floors- exposed, R-49 (1pt)
- Envelope: Windows 0.27 (1 pt)
- Envelope: Windows 0.25 (2 pts)
- Envelope: Windows 0.21 (3 pts)
- Envelope: Windows 0.18 (4 pts)
- Envelope: Doors – exterior, 0.26 (1 pt)
- ≤0.11 CFM50/Sq.Ft.(~1.5 ACH50) (1 pt)
- ≤0.07 CFM50/Sq.Ft.(~1.0 ACH50) (2 pt)
- ≤0.03 CFM50/Sq.Ft.(~0.5 ACH50) (3 pt)
- Balanced ventilation with ECM fans and ≥80% SRE and ≥1.2 cfm/watt (3 pts)
- Balanced ventilation with ECM fans and ≥70% SRE, and ≥2.0 cfm/watt (3 pts)
- Mechanical ventilation testing (1 pt)
- ENERGY STAR basic equipment (1 pt)
- HVAC (whole building) ENERGY STAR v.6 (5 pts)
- HVAC (whole building) is GSHP and ENERGY STAR labeled (10 pts)
- HVAC (whole building) is ATWHP COP≥2.5 (5 pts)
- Whole building heating/cooling is Advanced wood heating system from <http://www.rerc-vt.org> (5 pts)
- Hydronic distribution system meets building peak heating demand with 120-degree water (1 pt)
- All electric heating thermostats provided with demand responsive controls (1 pt)
- Electric Heat Pump Water Heater UEF ≥ 2.20 (3 pts)
- Electric Heat Pump Water Heater UEF ≥ 3.30 (5 pts)
- All showerheads ≤ 1.75 gpm, all lavatory faucets ≤ 1.0 gpm, and all toilets ≤ 1.28 gpc (1 pt)
- Certified water efficient design per WERS, WaterSense, or RESNET HERS_{H2O} (2 pts)
- Drain water heat recovery system on primary showers and tubs (1 pt)
- Controlled hot water recirculation system with user-demand via push-button for furthest fixtures (1 pt)
- All service hot water piping is insulated to at least R-4 from the hot water source to the fixture shutoff (1 pt)
- Electric storage water heater(s) provided with demand responsive controls (1 pt)
- Remote fixtures requiring hot water supplied from a localized source of hot water with no recirculating system (1 pt)
- Follow R402.7 Solar –ready zone requirements (base code only) (2 pts)
- Solar hot water system designed to meet at least 50% of the annual hot water load (2 pts)
- Solar PV (or other on-site renewable energy system), (1 pt per 1.5 kW, max. 4 pts)
- Whole-building energy monitoring system installed, minimum 5 circuits and homeowner access to data (1 pt)
- Radon mitigation system (1 pt)
- Building energy model with projected annual energy use and costs developed, used in design and construction decisions, and provided to homeowner (1 pt)
- Minimum 6 kWh grid-connected dispatchable demand-response-enabled battery (1 pt)
- Advanced lighting controls (2 pts)
- Insulation embodied carbon emissions calculated (1 pt)
- Insulation embodied carbon emissions: calculated GWP intensity (kg CO₂e/ft²) less than 0.5. (2 pts)
- Insulation embodied carbon emissions: calculated insulation GWP intensity (kg CO₂e/ft²) less than 0. (3 pts)
- Multifamily: Efficient elevator equipment (1 pt)
- Multifamily: Residential kitchen equipment (2 pts)
- Multifamily: Water heating system submeters (1 pt)

Thermal Envelope

Basement: R-_____ Basement / Crawl Space Walls _____ Basement Insulation Depth (ft) U-_____ Basement Windows NFRC Default

Slab: R-_____ Unheated Slab (Under) R-_____ Heated Slab (Under) R-_____ Perimeter Slab Edge

Wall/Ceiling: R-_____ Above-Grade Walls R-_____ Flat Ceilings _____ Area (sq ft) R-_____ Sloped Ceilings _____ Area (sq ft)

Other: R-_____ Floors over Unheated Spaces R-_____ Attic Access Hatch / Door NA

Fenestration U-_____ Windows NFRC Default U-_____ Doors NFRC Default U-_____ Skylights NFRC Default

Air Sealing / Blower Door Test

_____ CFM50
_____ ACH50
_____ CFM50/sq ft of building shell (6 sides)
Date of test _____
Air Leakage Tester Name: _____

Ventilation System Balanced, SRE _____ % CFM/watt: Flow verification: Rated, OR Measured → Exhaust air flow (total cfm) _____

Supply air flow (total cfm)
Other _____ Flow verification: Rated, OR Measured → Exhaust air flow (total cfm) _____

Combustion Safety

Exterior (outdoor) air supply is provided for solid fuel-burning appliances and fireplaces, OR NA (no solid fuel burning appliance or fireplace in home)

(verify all)

Solid fuel burning appliances and fireplaces have gasketed doors with compression closure, OR NA (no solid fuel burning appliance or fireplace in home)

Spillage testing conducted on combustion equipment not directly-vented, OR NA (no equipment, or all equipment directly-vented)

Mechanical System

Design Load Calculation Method: ACCA Manual J, OR Other Approved Method (List) _____

(must complete all)

Calculation details: (Ref. RBES R302 for design temperature exceptions)

_____ Winter design temp, outdoor dry-bulb (VT range: -11 to 1°F) _____ Summer design temp, outdoor dry-bulb (typ. max. 84°F), OR No cooling

_____ Winter design temp, indoor (max 72°F) _____ Summer design temp, indoor (min. 75°F), OR No cooling

_____ Heating design load, Btu/hr _____ Cooling design load, Btu/hr, OR No cooling

_____ Primary heating system size, Btu/hr _____ Primary cooling system size, Btu/hr, OR No cooling

_____ HSPF or COP or AFUE (circle which) _____ SEER or COP (circle which), OR No cooling

System type (ducted, hydronic, heat pump, space heater) _____

Fuel type _____

Programmable thermostat, OR Exempt; list reason

Ducts Ducts located completely within conditioned space, OR NA (no ducts)

Other Requirements Mandatory (Base and Stretch):

- Mechanical system piping, min. R-4
- 100% of lamps high efficacy
- Single-family: Solar ready

- Multi-family: One Level 2 capable EV-charging parking space
- Automatic or gravity dampers for vent. system intake and exhaust
- Single-family: One Level 2 capable EV-charging parking space

Mandatory (Stretch Code Only):

- Circulating service hot water controlled
- Pools: All requirements per R403.10 are met
- Automatic controls for snow-melt systems

Where applicable:

DRAFT

Instructions for Completing the ‘Vermont Residential Building Energy Standards Certificate’

Read these instructions in their entirety before completing the Vermont RBES Certificate for your home. Items are listed in **bold** in the order they appear on the certificate.

1. List the **Property Address**, including the **City** and **Zip code**.
2. List the **Construction START** and **Construction FINISH** dates by **Month/Year**. **Construction START** is when site work began, when the ground was first dug to prepare for a below grade foundation or slab on grade, etc. **Construction FINISH** is when the dwelling is sufficiently ready for occupancy.
3. If the dwelling received an **Act 250 Permit**, write in “**Yes**” and list the **Act 250 Permit #**. If not, write “**No**”.
4. Project Description: Multifamily homes: Write in the number of **Units**. For all Projects, write in the number of **Stories** above grade, and the **Square feet** of area within the thermal enclosure, which includes unconditioned spaces such as an unheated basement, as long as they are within the insulated and air sealed area of the home. Do not include heated garages in this calculation. Write in the **Number of Bedrooms**. For Existing Homes Project Description include a brief description of the work done.
5. **Foundation Type**: Check all that apply.
6. In the box located in the middle of page one, check **Base** or **Stretch** code, and mark which type of home it is (Single family, Multifamily, Log home) and also whether it is a Renovation/ alteration, Addition or Repair.
7. Under the certification section, list the name of the **Owner** of the dwelling. Write in the Date (month and year) the certificate is signed and completed. The **Signature** is either the builder who directed construction or another party authorized to certify Code compliance. The Printed Name is that of the person whose Signature is presented (the builder or other authorized party to certify Code compliance). **Company**: List the business name of the party certifying compliance. List the **Phone** number of the **Company** certifying compliance (including area code).
8. Under **Compliance Method**, check the compliance path by which you determined technical compliance with the Code. You must select Option 1, 2, or 3.
 - **Option 1: Package-Plus-Points:**
 - Circle **BASE** or **STRETCH**
 - Fill in the Package # you utilized, and the Points required (based on square footage) and Points achieved. A simplified overview of points is provided in the Certificate for your ease of reference. For full requirements, review the Handbook.
 - **Option 2: REScheck™ software:**
 - List the **REScheck™** software UA result and Max. UA for your home calculated by **REScheck™**.
 - **Option 3: HERS/ERI:** If compliance is determined using a home energy rating,
 - List the **HERS Result (Overall)** and the **HERS without Renewables result**,
 - List the **REM/Rate Version # and verify that Index Adjustment Factor (IAF)** was included in the result
 - List the Approved Rater Name.

10. **Package-Plus-Points:** Check all applicable package-plus-points options that were utilized in your project.
11. **Thermal Envelope:** Where applicable, list the nominal R-value of the insulation. If any component has more than one R-value (e.g., R-38 ceiling and R-49 ceiling), calculate an average R-value and enter that figure on the form. (See Section C.5, “How to Calculate Average R-values and U-factors.”) For basement walls, list the vertical height of the basement insulation in **Basement Insulation Depth** in feet (ft.). Where applicable, list the U-factor for fenestration. If the U-factor is not an **NFRC (National Fenestration Rating Council) Rating**, list the **Default Rating** (refer to Appendix B, Tables B-1 and B-2). Check rating type for windows and skylights — either **NFRC or Default Rating**.
12. **Air Sealing/Blower Door Test:** Report CFM50, ACH50, and CFM50/sq. ft. of the six-sided building shell area. Include the **building volume used** in calculating ACH50 and the 6-side building thermal shell area used in calculating CFM50/sq. ft. **Provide the Blower Door Result, Date of Test and the Air Leakage Tester Name.**
13. **Ventilation System:** Note the SRE% and the rated or measured supply and exhaust flow rates.
14. **Combustion Safety:** Check if **exterior (outdoor) air supply** requirements have been met for solid fuel-burning appliances and fireplaces or mark **NA** to verify that no solid fuel-burning appliances or fireplaces exist in the home. Check if **solid fuel burning appliances and fireplaces** have gasketed doors with compression closure or mark **NA**. Check if **spillage testing was conducted on combustion equipment that is not directly vented or mark NA.**
15. **Mechanical System:** Identify the **Design Load Calculation Method** used: check **ACCA Manual J** or fill in the Other Approved Method used. Fill in the **Calculation details** by writing in the result or marking the appropriate answer (e.g. No cooling). Check **Programmable thermostat** or list the **reason** for exemption. Note that the **heating (and cooling, if modeled) design temperatures used in the calculations must be listed.**
16. **Ducts:** Check if ducts are **located completely within conditioned space** or mark **NA** if there are no ducts.
17. **Other Requirements:** Check all that apply.
18. Under the certification section, list the name of the **Owner** of the dwelling. Write in the Date (month and year) the certificate is signed and completed. The **Signature** is either the builder who directed construction or another party authorized to certify Code compliance. The Printed Name is that of the person whose Signature is presented (the builder or other authorized party to certify Code compliance). **Company:** List the business name of the party certifying compliance. List the **Phone** number of the **Company** certifying compliance (including area code).

Section 9.2b

Filing the ‘Vermont Residential Building Energy Standards Certificate’

Once the certificate is completed, you need to file the required copies and attach the original to the house:

1. Make at least three copies of the completed certificate, retaining one for your records.
2. Attach the original certificate to the house by permanently affixing it on or near the electrical service panel or heating equipment, without covering or obstructing the visibility of the circuit directory label, service disconnect label or other required labels.
3. Within 30 days of completing construction, send one copy each to:
 - The Town Clerk for the town or city in which the home is located. (Note: Check local procedures before filing the certificate; local fees and forms may be required.)
 - The Vermont Public Service Department Efficiency & Energy Resources Division
112 State Street
Montpelier VT 05620-2601

To order additional certificates, contact one of these resources:

★ Energy Code Assistance
Center
1-855-887-0673.

★ Vermont Public Service
Department
1-802-828-2811.

Section 9.3

The ‘Vermont Owner/Builder Disclosure Statement’

As outlined in Section 1.4, “Owner/builder” projects are exempt from the technical requirements of the Code, but the owner/builder must meet certification requirements by completing and filing a disclosure statement. To qualify for this provision, all of the following criteria must be met:

1. The property must not be subject to Act 250.
2. The owner must be the person in charge of construction (i.e., the “general contractor”), directing the details of construction and the selection and installation of materials.
3. The owner must live in the building.
4. The owner must evaluate whether the home meets the Residential Building Energy Standards.
5. Depending on whether the home meets the technical requirement of the Energy Code, the owner must complete one of two documents: either the Vermont Residential Building Energy Standards Certificate if the home meets the technical requirements, or the Vermont Owner/Builder Disclosure Statement if it does not.

Before entering into a binding purchase and sale agreement, the owner must disclose in writing (using the Owner-Builder Disclosure Form) to a prospective buyer the nature and extent of any non-compliance with the Energy Code.

Section 9.3a

Instructions for Completing the ‘Vermont Owner/Builder Disclosure Statement’

Read the instructions in their entirety before completing the Vermont Owner/Builder Disclosure Form. (See sample on the next page.) This Form is very similar to the Vermont Residential Building Energy Standards Certificate in Section 8.2; follow the instructions in Section 8.2a to fill out either one. There are only three differences between the two forms:

1. The Vermont Owner/Builder Disclosure Statement cannot be used for Act 250 projects. (Act 250 projects must meet the technical requirement of the Residential Building Energy Standards.)
2. The signature area on this form does not include a space for you to list a company name.
3. This form states that the home does not meet the Energy Code’s technical requirement.

Section 9.3b

Filing the Vermont Owner/Builder Disclosure Statement

If you are using the form to notify a potential buyer, you must do so before entering into a binding purchase and sales agreement. The process for filing this statement is identical to that for the Vermont Residential Building Energy Standards Certificate (Section 8.2).

Figure 9.2: The Vermont Owner/Builder Disclosure Statement.

2024 Vermont Owner/Builder Disclosure Statement (Pg 1)

This disclosure statement is for projects started on or after July 1, 2024. This home does not meet the technical requirements of the Vermont Residential Building Energy Standards (RBES) and is not required to do so.

For additions, alterations, renovations or repairs, only fill out applicable portions of certificate.

Property Address (Street, City, ZIP Code) _____

Construction START Date _____

Construction FINISH Date _____

Act 250 (Y/N) _____

Act 250 Permit # _____

Units _____

Stories _____

Conditioned Sq. Ft. _____

Bedrooms _____

Foundation: Basement Slab On Grade Crawl Space Other: _____

Applicable Code: Base Stretch

Project Description

Single family

Renovation / alteration*

Multi-family

Addition*

*Existing Home Project Description: _____

I certify that the above information is correct and that the premises listed **HAVE NOT been constructed in accordance** with the Vermont Residential Building Standards (RBES) created under 30 V.S.A. § 51.

Signature: _____ Date: _____

Printed Name: _____ Phone: _____

For Owner/Builder Projects, 30 V.S.A. § 51 requires sellers to provide this statement to prospective buyers, prior to entering a binding purchase and sale agreement. This statement itemizes how the home DOES NOT comply with Vermont RBES. Seller must send copies within 30 days following the sale of the property to 1) the Dept. of Public Service, 112 State St., Montpelier, VT 05602 and 2) the town clerk of the town where the property is located. This label does not specify all 2024 RBES requirements.

QUESTIONS? CALL the Energy Code Assistance Center at 855-887-0673 or the VT PUBLIC SERVICE DEPARTMENT at 802-828-2811.

Town clerk recording stamp

SPAN # _____

For copies of this form, photocopy this page or contact the Energy Code Assistance Center (855-887-0673).

2024 Vermont Owner/Builder Disclosure Statement (Pg 2)

Compliance Method:
MUST select Option 1,
Option 2, or Option 3

Option 1: Package-Plus-Points

BASE / STRETCH (circle one)
Package # _____
Points required: _____
Points achieved: _____
(Base requires up to 10pts/ Stretch up to 15pts, see Handbook Tables 5-2 and 5-5)
Ref. RBES for full reqs. of each point option

Option 2: REScheck software (cannot be used for Stretch Code) Passes
_____ UA result _____ Max. UA

Option 3: HERS/ERI

_____ HERS Result (Overall)
_____ HERS without Renewables
_____ HERS software used, version #
(BOX) IAF incorporated into model
Approved rater name: _____
(Maximum HERS 60 Base, 59 Stretch)

- Envelope: Slab, R-20 around perimeter and below entire slab (2 pts)
- Envelope: Walls-R-28 2x6 cavity insulation with continuous (1 pt)
- Envelope: Walls- R-35 double stud or similar (cavity and continuous) (2 pts)
- Envelope: Walls- R-40 double stud or similar (cavity and continuous) (3 pts)
- Envelope: R-48 SIP 10 1/4" XPS or similar (cavity and continuous) (4 pts)
- Envelope: Ceiling, R-60 flat / 49 sloped (1 pt)
- Envelope: Ceiling, R-80 flat / 60 sloped (2 pts)
- Envelope: Floors- exposed, R-49 (1pt)
- Envelope: Windows 0.27 (1 pt)
- Envelope: Windows 0.25 (2 pts)
- Envelope: Windows 0.21 (3 pts)
- Envelope: Windows 0.18 (4 pts)
- Envelope: Doors – exterior, 0.26 (1 pt)
- ≤0.11 CFM50/Sq.Ft.(~1.5 ACH50) (1 pt)
- ≤0.07 CFM50/Sq.Ft.(~1.0 ACH50) (2 pt)
- ≤0.03 CFM50/Sq.Ft.(~0.5 ACH50) (3 pt)
- Balanced ventilation with ECM fans and ≥80% SRE and ≥1.2 cfm/watt (3 pts)
- Balanced ventilation with ECM fans and ≥70% SRE, and ≥2.0 cfm/watt (3 pts)
- Mechanical ventilation testing (1 pt)
- ENERGY STAR basic equipment (1 pt)
- HVAC (whole building) ENERGY STAR v.6 (5 pts)
- HVAC (whole building) is GSHP and ENERGY STAR labeled (10 pts)
- HVAC (whole building) is ATWHP COP≥2.5 (5 pts)
- Whole building heating/cooling is Advanced wood heating system from <http://www.rerc-vt.org> (5 pts)
- Hydronic distribution system meets building peak heating demand with 120-degree water (1 pt)
- All electric heating thermostats provided with demand responsive controls (1 pt)
- Electric Heat Pump Water Heater UEF ≥ 2.20 (3 pts)
- Electric Heat Pump Water Heater UEF ≥ 3.30 (5 pts)
- All showerheads ≤ 1.75 gpm, all lavatory faucets ≤ 1.0 gpm, and all toilets ≤ 1.28 gpc (1 pt)
- Certified water efficient design per WERS, WaterSense, or RESNET HERS_{H2O} (2 pts)
- Drain water heat recovery system on primary showers and tubs (1 pt)
- Controlled hot water recirculation system with user-demand via push-button for furthest fixtures (1 pt)
- All service hot water piping is insulated to at least R-4 from the hot water source to the fixture shutoff (1 pt)
- Electric storage water heater(s) provided with demand responsive controls (1 pt)
- Remote fixtures requiring hot water supplied from a localized source of hot water with no recirculating system (1 pt)
- Follow R402.7 Solar –ready zone requirements (base code only) (2 pts)
- Solar hot water system designed to meet at least 50% of the annual hot water load (2 pts)
- Solar PV (or other on-site renewable energy system), (1 pt per 1.5 kW, max. 4 pts)
- Whole-building energy monitoring system installed, minimum 5 circuits and homeowner access to data (1 pt)
- Radon mitigation system (1 pt)
- Building energy model with projected annual energy use and costs developed, used in design and construction decisions, and provided to homeowner (1 pt)
- Minimum 6 kWh grid-connected dispatchable demand-response-enabled battery (1 pt)
- Advanced lighting controls (2 pts)
- Insulation embodied carbon emissions calculated (1 pt)
- Insulation embodied carbon emissions: calculated GWP intensity (kg CO₂e/ft²) less than 0.5. (2 pts)
- Insulation embodied carbon emissions: calculated insulation GWP intensity (kg CO₂e/ft²) less than 0. (3 pts)
- Multifamily: Efficient elevator equipment (1 pt)
- Multifamily: Residential kitchen equipment (2 pts)
- Multifamily: Water heating system submeters (1 pt)

Thermal Envelope

Basement: R-_____ Basement / Crawl Space Walls _____ Basement Insulation Depth (ft) U-_____ Basement Windows NFRC Default

Slab: R-_____ Unheated Slab (Under) R-_____ Heated Slab (Under) R-_____ Perimeter Slab Edge

Wall/Ceiling: R-_____ Above-Grade Walls R-_____ Flat Ceilings _____ Area (sq ft) R-_____ Sloped Ceilings _____ Area (sq ft)

Other: R-_____ Floors over Unheated Spaces R-_____ Attic Access Hatch / Door NA

Fenestration U-_____ Windows NFRC Default U-_____ Doors NFRC Default U-_____ Skylights NFRC Default

Air Sealing / Blower Door Test

_____ CFM50 Date of test _____
_____ ACH50 Air Leakage Tester Name: _____
_____ CFM50/sq ft of building shell (6 sides)

Ventilation System

Balanced, SRE _____ % CFM/watt: Flow verification: Rated, OR Measured → Exhaust air flow (total cfm) _____
Supply air flow (total cfm) _____
Other _____ Flow verification: Rated, OR Measured → Exhaust air flow (total cfm) _____

Combustion Safety

Exterior (outdoor) air supply is provided for solid fuel-burning appliances and fireplaces, OR NA (no solid fuel burning appliance or fireplace in home)

(verify all) Solid fuel burning appliances and fireplaces have gasketed doors with compression closure, OR NA (no solid fuel burning appliance or fireplace in home)

Mechanical System

Spillage testing conducted on combustion equipment not directly-vented, OR NA (no equipment, or all equipment directly-vented)

Design Load Calculation Method: ACCA Manual J, OR Other Approved Method (List) _____

(must complete all) Calculation details: (Ref. RBES R302 for design temperature exceptions)

_____ Winter design temp, outdoor dry-bulb (VT range: -11 to 1°F) _____ Summer design temp, outdoor dry-bulb (typ. max. 84°F), OR No cooling

_____ Winter design temp, indoor (max 72°F) _____ Summer design temp, indoor (min. 75°F), OR No cooling

_____ Heating design load, Btu/hr _____ Cooling design load, Btu/hr, OR No cooling

_____ Primary heating system size, Btu/hr _____ Primary cooling system size, Btu/hr, OR No cooling

_____ HSPF or COP or AFUE (circle which) _____ SEER or COP (circle which), OR No cooling
System type (ducted, hydronic, heat pump, space heater) _____
Fuel type _____
 Programmable thermostat, OR Exempt; list reason _____

Ducts Ducts located completely within conditioned space, OR NA (no ducts)

- Other Requirements Mandatory (Base and Stretch):** Mechanical system piping, min. R-4 Multi-family: One Level 2 capable EV-charging parking space
 100% of lamps high efficacy Automatic or gravity dampers for vent. system intake and exhaust
- Mandatory (Stretch Code Only):** Single-family: Solar ready Single-family: One Level 2 capable EV-charging parking space

Where applicable: Circulating service hot water controlled Pools: All requirements per R403.10 are met Automatic controls for snow-melt systems

DRAFT

Additional Minimum Stretch Code Requirements

Section A.1

Package Plus Points

The Stretch Code envelope and fenestration requirements are listed above in Section 6.3.

Section A.2

Home Energy Rating Compliance Method

Home Energy Rating System (HERS) index requirements for Stretch Code, as detailed in Chapter 8, are a maximum HERS index of 59, with up to 5 of these points that may be achieved with renewables. When using the HERS compliance method for stretch code, the building must comply with Sections A.3 through A.5.

Section A.3

Air Leakage Testing

Buildings subject to the Stretch Code must be tested in the same way as those under Base Code (see Section 3.1).

Section A.4

Electric Vehicle (EV) Charging

Buildings subject to the Stretch Code must meet the same EV Charging requirements as buildings subject to the Base Code (see Section 3.9).

Section A.5

Solar Ready Zone

New detached one- and two-family dwellings, and multiple single family dwellings (townhouses) with not less than 600 ft² (55.74 m²) of roof area oriented between 110° and 270° of true north must comply.

The following are exceptions to the Solar Ready Zone requirement:

1. New residential buildings with a permanently installed on-site renewable energy system.
2. A building with a solar-ready zone that is shaded for more than 70% of daylight hours annually.
3. Buildings and structures as designed and shown in construction documents that do not meet the conditions for a solar-ready zone area.
4. Buildings with possible location(s) for ground mounted systems identified in the submitted construction documents. Buildings claiming this exception must either install appropriate electrical conduit to the site of the proposed ground mounted solar array or include a solar site evaluation that supports the siting of the proposed ground mounting location.

Section A.5a

Construction Document Requirements for Solar Ready Zone

Construction documents shall indicate the solar ready zone where applicable.

Section A.5b

Solar-Ready Zone Area

The total solar-ready zone area shall consist of an area not less than 300 ft² (27.87 m²) exclusive of mandatory access or set back areas. New multiple single-family dwellings (townhouses) three stories or less in height above grade plane and with a total floor area less than or equal to 2,000 ft² (185.8 m²) per dwelling shall have a solar-ready zone area of not less than 150 ft² (13.94 m²). Multifamily buildings should maximize the solar-ready zone by consolidating mechanicals, access, set back areas and other roof obstructions with a goal of 40% of the roof area available for the solar-ready zone. The solar-ready zone shall be composed of areas not less than five feet (1,524 mm) in width and not less than 80 ft² (7.44 m²) exclusive of access or required set back areas.

For ground-mounted systems, possible locations of the panels must be identified in the submitted construction documents and be supported by a solar site evaluation. At least one potential location must be identified in the construction documents for the future installation of the panels.

Section A.5c

Obstructions

Solar-ready zones shall consist of an area free from obstructions, including but not limited to vents, chimneys, and roof-mounted equipment.

Section A.5d

Roof Load Documentation

The structural design loads for roof dead load and roof live load to support the solar system shall be clearly indicated on the construction documents.

DRAFT

Section A.5e

Interconnection Pathway

Construction documents shall indicate pathways for routing of conduit (or plumbing for solar thermal systems) from the solar-ready zone to the electrical service panel or service hot water system. Alternatively, install two 1" minimum diameter EMT conduits from the main electrical panel location to the attic or other area easily accessible to the solar array's proposed location. Conduits for future solar installations are to be capped, airtight and labeled at both ends.

Section A.5f

Electrical Service Reserved Space

The main electrical service panel shall have a reserved space to allow installation of a dual pole circuit breaker for future solar electric installation and shall be labeled "For Future Solar Electric." The reserved space shall be positioned at the opposite (load) end from the input feeder location or main circuit location. **Note:** this requirement is in addition to the electrical service reserved space for electric vehicle charging. This requirement is only for the building master panel and not individual dwelling unit panels in the case of multifamily buildings.

Section A.5g

Electrical Energy Storage System-Ready Area

The floor area of the electrical energy storage system-ready area shall be not less than 2'x4'. The location and layout of the electrical energy storage system-ready area shall be indicated on the construction documents.

Default Values

The tables in this appendix can be used to determine thermal and efficiency values for building components when those values are not labeled or when they are unknown. Default thermal and efficiency values in this appendix include:

| Component | Table to Use | Values Provided in Table |
|---------------------------------------|----------------|--------------------------|
| Windows, glazed doors, skylights..... | Table B-1..... | U-Factors |
| Doors..... | Table B-2..... | U-Factors |

Table B-1

| U-Values for Windows & Skylights ⁶ | | | | |
|---|-------------|-------------|----------|--------|
| FRAME TYPE | SINGLE PANE | DOUBLE PANE | SKYLIGHT | |
| | | | Single | Double |
| Metal | 1.20 | 0.80 | 2.00 | 1.30 |
| Metal with Thermal Break | 1.10 | 0.65 | 1.90 | 1.10 |
| Nonmetal or Metal Clad | 0.95 | 0.55 | 1.75 | 1.05 |
| Glazed Block | 0.60 | | | |

Table B-2

| U-Values for Doors | |
|--|----------|
| DOOR TYPE | U-FACTOR |
| Uninsulated Metal | 1.20 |
| Insulated Metal | 0.60 |
| Wood | 0.50 |
| Insulated, nonmetal edge, max 45% glazing, any glazing double pane | 0.35 |

⁶The U-factors in these tables can be used in the absence of tested U-factors. The product cannot receive credit for a feature that cannot be clearly detected. Where a composite of materials from two different product types is used, the product must be assigned the higher U-factor.

Appendix C

.....

Guidelines for Calculations

Some calculations must be performed in order to determine technical compliance with the Vermont Residential Energy Code. In order to use the Package Plus Points Prescriptive method, you may need to calculate average R-values or U-factors for one or more building components.

Section C.1

When to Perform Calculations

There are three times the required calculations should be performed:

1. **At the Planning Stage:** During the design stage, take building dimensions and insulation characteristics from the building plans, specifications and drawings. (You will use these values to determine whether the building meets the Package Plus Points Prescriptive Requirements for the compliance path you select.)
2. **In the Event of Design Changes:** If there are any changes to the energy-related components of a project, you will need to determine whether the building still meets the technical requirement of the Energy Code.
3. **After Completion:** Upon completion of construction, determine whether the as-built home differs from the original design. If building dimensions, window thermal properties, R-values, or U-factors change, you will need to review your calculations in order to determine whether the building meets the Package Plus Points Prescriptive Requirements.

Section C.2

How to Define the Building Envelope

The thermal requirements of the Energy Code pertain to all surfaces of the building envelope, so it is important to understand the definition and extent of the building envelope in a house.

The building envelope includes all components of a building that enclose conditioned spaces, even if it is not currently heated or cooled (e.g. an unfinished basement without heat but that could be heated later on since the foundation walls are insulated and it's inside the thermal envelope). Building envelope components separate conditioned spaces from unconditioned spaces or from outside air. For

example, walls and doors between an unheated garage and a living area are part of the building envelope; walls separating an unheated garage from the outside are not.

Although floors of conditioned basements and conditioned crawl spaces are technically part of the building envelope, the Energy Code does not always specify insulation requirements for these components. Thus, except for the walkout portion of a conditioned basement (which is treated as a “slab on grade” and needs perimeter insulation), you can ignore these components when determining the building envelope. See Appendix F, “Definitions,” for more information.

DRAFT

Section C.3

Understanding Thermal Values

In order to meet the technical requirements of the Energy Code, you need to determine the thermal value of various building components. The thermal performance of all components except windows and doors is expressed in terms of R-value; for windows and doors, performance is expressed in terms of *U-factor*.

Section C.3a

R-value

R-values are specified in the Residential Building Energy Standards for all building components except windows and doors. The higher a component's R-value, the better insulation (i.e., resistance to heat flow) it provides.

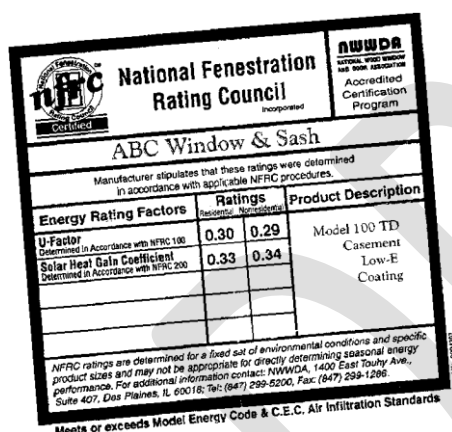
Use the nominal R-values as listed by the manufacturer on the packaging of the insulation for determining compliance with the Energy Code. (For loose-fill insulation, the R-value per inch of thickness for a given area of coverage is listed on the bag.)

Section C.3b

U-factor

Windows and doors are labeled in U-factor. A U-factor is the measure of how well a component *conducts* heat. A smaller U-factor results in lower heat flow, and therefore less heat loss. Higher U-factor mean greater heat loss. The U-factor is the reciprocal of the R-value, which is the *resistance* to heat flow ($U\text{-factor} = 1/R\text{-value}$).

To determine the U-factor for glazing and doors in your building project, refer to the tables in Appendix B or use the values supplied by the manufacturer, *provided* the label states that the U-factor has been tested and documented in accordance with the National Fenestration Rating Council (NFRC) test procedures. *Do not use center-of-glass or center-of-door U-factor.*



▲ Example of a manufacturer's NFRC label showing the window U-factor.

Section C.4

How to Calculate Average R-values and U-factor

Section C.4a

Average R-values

If a home has two different types of thermal values for a single component (such as an R-38 and an R-49 flat ceiling) and you want to use the Package Plus Points Prescriptive method, you must average the two thermal values in order to arrive at one component value. This single R-value is then compared to the required R-value in the appropriate table.

Use the following procedure to determine the average R-value for a building component with two or more thermal values:

1. Note the description and R-value of each of the parts.
2. Divide 1 by this R-value; the resulting figure becomes the U-factor. (U-factor = 1/R)
3. Determine the area of this portion of the building component in square feet.
4. Multiply the U-factor by the area; the product is the "UA" for this part.
5. Repeat steps 1-4 for each additional part.
6. Add up the total UAs (#4) and the areas (#3).
7. Divide the total area by the total UA; this is the average R-value.

Example: Determining the Average Attic R-value

Lets say part of your attic is R-38 and the other part is R-60. The total attic area is 1,000 square feet. The average R-value is calculated at 49.9.

| Description | R-value | U-factor (1/R-value) | Area | U-factor x Area "UA" |
|---|---------|-------------------------|----------------------|-------------------------|
| Attic 1 | 38 | 0.026 | 350 | 9.2 |
| Attic 2 | 60 | 0.017 | 650 | 10.8 |
| | | | Total Area = 1000 | Total UA = 20.0 |
| Area / UA = Average R-value 1000 / 20.0 = 49.9 | | | | |

$$\text{Area} / \text{UA} = \text{R-value}$$

Section C.4b

Average U-factors

For windows and doors — which use U-factors rather than R-values — the calculation is the same, except there is no need to convert R-values to U-factors and back again. The procedure is as follows:

Example: Determining the Average Window U-factors

Lets say that you have 16 low-E windows (U-value 0.30), and a low-E/argon gas patio door (U-value 0.32). The average U-value is calculated to be 0.30.

| Description | R-value | U-value (1/R-value) | Area | U-value x Area "UA" |
|--|---------|------------------------|---------------------|------------------------|
| Windows | | 0.30 | 240 | 72.0 |
| Patio Door | | 0.32 | 40 | 12.8 |
| | | | Total Area = 280 | Total UA = 84.8 |
| UA / Area = Average U-value 84.8 / 280 = 0.30 | | | | |

$$\text{UA} / \text{Area} = \text{U-factor}$$

1. Note the description and U-factor of each of the parts.
2. Determine the area of this portion of the building component in square feet.
3. Multiply the U-factor by the area; this becomes the UA for that part.
4. Repeat steps 1-3 for each additional part.
5. Add up the total UAs (#3) and the areas (#2).
6. Divide the total UA by the total area; this is the average U-factor.

DRAFT

Cavity-Only Wall Insulation Exception: Examples

As noted in Chapter 6, while not recommended, the 2024 RBES allows for an exception from meeting the U-factor for walls listed in Table 6-1 (U-0.044). Building cavity-only 2x6 walls may be insulated to the manufacturer’s installation standards with at least R-20 insulation without additional continuous or other insulation. To make up for the lower performance of these walls, you must *achieve five (5) points in addition to the points required* from Table 6-2 above. Table D-1 presents three different example packages that could be used to meet the points required in this scenario. *Please note that these are only examples, any combination of components from Table 6-3 can be used to meet the total points required from Table 6-2 and the additional five points required by the cavity-only exemption.*

Alternatively, the REScheck (Chapter 7) or Home Energy Rating (Chapter 8) approaches could also be used to comply with 2x6 cavity-only walls.

Table D-1. Example 2x6 Cavity-Only Points Combinations

| Examples: Package-Plus-Points Combinations with 2x6 Cavity-Only Exception | | | | | | |
|--|---|---------------|---|---------------|---|---------------|
| <i>Home Type and Size</i> | Single-Family Home < 2,500 square feet | | Single-Family Home < 2,500 square feet | | Single-Family Home 2,500 to 4,000 square feet | |
| <i>Base Code Required Points (a)</i> | 5 | | 5 | | 7 | |
| <i>2x6 Cavity-Only Exception Required Points (b)</i> | 5 | | 5 | | 5 | |
| <i>Total Required Points (c=a+b)</i> | 10 | | 10 | | 12 | |
| Component | Example 1 | Points | Example 2 | Points | Example 3 | Points |
| Envelope - Ceiling | R-60 attic flats (U-0.018) and R-49 slopes, vaulted and cathedral (U-0.020) | 1 | R-49 attic flats (U-0.020) and R-44 slopes, vaulted and cathedral (U-0.025) | 0 | R-60 attic flats (U-0.018) and R-49 slopes, vaulted and cathedral (U-0.020) | 1 |
| Envelope - Above Grade Wall | R-20 2x6, 16oc, FG U-0.060 | 0 | R-20 2x6, 16oc, FG U-0.060 | 0 | R-20 2x6, 16oc, FG U-0.060 | 0 |
| Envelope - Frame Floor | U-0.029: R-38 | 0 | U-0.029: R-38 | 0 | R-49 (U-0.021) | 1 |
| Envelope - Basement/Crawl Space Walls | R-20ci OR R-13+10ci | 0 | R-20ci OR R-13+10ci | 0 | R-20ci OR R-13+10ci | 0 |

| | | | | | | |
|---|---|-----------|--|-----------|---|-----------|
| Envelope - Slab, on grade | R-20,4' (edge) OR R-15,4'(edge) + R-7.5 (under entire slab) | 0 | R-20,4' (edge) OR R-15,4'(edge) + R-7.5 (under entire slab) | 0 | R-20,4' (edge) OR R-15,4'(edge) + R-7.5 (under entire slab) | 0 |
| Envelope - Windows | Average U-factor \leq 0.27 | 1 | U-0.30 | 0 | Average U-factor \leq 0.25 | 2 |
| Envelope - Doors (Exterior) | U-0.26 | 1 | U-0.37 | 0 | U-0.26 | 1 |
| Air Leakage - Tighter | Tested to \leq 0.07 CFM50/Sq. Ft. of Building Shell (6-sided) (~1.0 ACH50) | 2 | Tested to \leq 0.07 CFM50/Sq. Ft. of Building Shell (6-sided) (~1.0 ACH50) | 2 | Tested to \leq 0.07 CFM50/Sq. Ft. of Building Shell (6-sided) (~1.0 ACH50) | 2 |
| Mechanical Ventilation - Better Heat Recovery | Balanced ventilation with ECM fans and \geq 80% SRE and \geq 1.2 cfm/watt | 3 | n/a | 0 | Balanced ventilation with ECM fans and \geq 80% SRE and \geq 1.2 cfm/watt | 3 |
| Heating and Cooling - Cold Climate Air Source Heat Pump | n/a | 0 | Whole building heating /cooling is ENERGY STAR v.6 labeled | 5 | n/a | 0 |
| Heating and Cooling - Demand Responsive Thermostats | All electric heating thermostats provided with demand responsive controls | 1 | n/a | 0 | All electric heating thermostats provided with demand responsive controls | 1 |
| Water - Heat Pump Basic | n/a | 0 | Electric Heat Pump Water Heater UEF \geq 2.20 | 3 | n/a | 0 |
| Water - Low flow | All showerheads \leq 1.75 gpm, all lavatory faucets \leq 1.0 gpm, and all toilets \leq 1.28 gpf | 1 | n/a | 0 | All showerheads \leq 1.75 gpm, all lavatory faucets \leq 1.0 gpm, and all toilets \leq 1.28 gpf | 1 |
| <i>Total Points Achieved</i> | | <i>10</i> | | <i>10</i> | | <i>12</i> |

Vermont Resources for Energy Efficiency & Utility Services

Energy Code Assistance Center

For questions, information, software and other Code-related materials, call the Energy Code Hotline toll-free at 855-887-0673.

The Energy Code Assistance Center offers workshops on the Code throughout Vermont to teach builders what the Code involves and how to comply. The schedule is available by calling the Energy Code Hotline.

Residential Energy Code Web Site

For more detail and background on the Vermont Residential Buildings Energy Code, check the web site maintained by the Public Service Department at <http://publicservice.vermont.gov>.

Burlington Electric Department:

The Burlington Electric Department (BED) is Vermont's largest municipally owned electric utility serving more than 19,600 customers. BED is the exclusive provider of electric service to the City of Burlington. Information: 802-865-7300 or www.burlingtonelectric.com.

Building Performance Professionals Association

BPPA supports and represents its members as we work to promote Vermont's building performance industry and to ensure the energy efficiency, comfort and safety of our residential and commercial buildings. www.bpps-vt.org

Efficiency Vermont

Efficiency Vermont is the nation's first statewide provider of energy-efficiency services. Efficiency Vermont provides technical advice, financial assistance and design guidance to help make Vermont homes, farms and businesses energy efficient. Information: 888-921-5990 or efficiencyvermont.com.

Vermont Builders & Remodelers Association

Since 1957, the Vermont Builders and Remodelers Association has been Northern Vermont's Trade Association. They are actively involved in building issues and other activities in support of the building industry. Information is at <https://www.homebuildersvt.com/>

American Institute of Architects - Vermont AIA-VT

represents and supports architects and building in Vermont. Information is at <https://www.aiavt.org/>.

Vermont Public Service Department

The Vermont Public Service Department (PSD), Planning & Energy Resources Division, is responsible for the administration of the Residential Energy Code. For questions regarding Code interpretation, rules and enforcement, contact PSD at 802-828-2811.

VEIC

Vermont Energy Investment Corp. is the nonprofit organization that operates Efficiency Vermont for the State of Vermont. Contact VEIC at 800-639-6069.

Vermont Gas Systems

Vermont Gas Systems supplies natural gas service to northwestern Vermont and has provided energy-efficiency programs since 1992. If you're building a new home, trying to save energy in an existing home, or installing a new furnace, boiler or hot water heater, Vermont Gas has efficiency experts on staff and energy-efficiency programs to help you make the best decisions for your specific situation. Information: 802-863-4511 or www.vermontgas.com.

Builder Tax Credit

Eligible contractors who build or substantially reconstruct qualified new energy-efficient homes may be able to claim tax credits up to \$5,000 per home. The amount of the credit depends on factors including the type of home, its energy efficiency, and the date when the home is acquired. More information can be found here: <https://www.irs.gov/credits-deductions/credit-for-builders-of-energy-efficient-homes>

Call to Action – Utilizing HERS Raters

Contractors are encouraged to reach out to the local HERS rating community for support in complying with the 2024 RBES requirements. HERS raters are trained to understand these code requirements and to support builders in identifying the most cost-effective and practical solutions to achieving code compliance

Residential Building Energy Standards Statute

The Vermont Residential Energy Code (officially “Residential Building Energy Standards” or “RBES”), is Vermont’s statewide residential energy code. Created by a task force assembled by Governor Howard Dean in the fall of 1995, the Residential Energy Code was enacted by the Vermont Legislature (Act 20) in May 1997 with the support of many groups and organizations, including home builders’ associations, utilities, environmental groups, housing and energy professionals, and state agencies. The initial Residential Energy Code took effect July 1, 1997.

The RBES Statute, VSA 30§51, calls for the code to be updated promptly after the issuance of updated standards for residential construction under the International Energy Conservation Code® (IECC).

The Fifth Edition of the Vermont Residential Building Energy Standard (RBES) is based on the language in the 2015 edition of the IECC and includes all of the efficiency improvements included in IECC 2018 as well as some of the improvements proposed for IECC 2021 to insure continued progression in efficiency in the Vermont RBES. The Vermont RBES are designed to promote the optimal utilization of energy and non-depletable resources in all communities, large and small. This comprehensive energy conservation code establishes minimum regulations for energy-efficient buildings using prescriptive and performance-related provisions. RBES is founded on broad-based principles that make possible the use of new materials and energy-efficient designs.

For More Information

For additional information about the legislation, contact the Vermont Public Service Department (PSD) at 802-828-2811. For a copy of the complete legislation and more detail on the Code, visit the PSD web site at <https://publicservice.vermont.gov/content/building-energy-standards>.

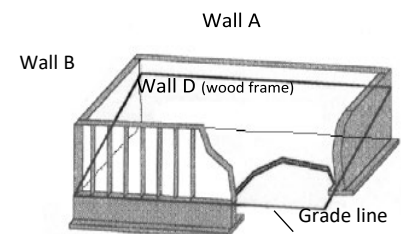
Appendix G

Definitions

| | |
|--------------------|---|
| Above Grade Wall | A wall more than 50% above grade and enclosing <i>conditioned space</i> . This includes between-floor spandrels, peripheral edges of floors, roof and basement knee walls, dormer walls, gable end walls, walls enclosing a mansard roof and skylight shafts. |
| Accessible | Admitting close approach as a result of not being guarded by locked doors, elevation or other effective means (see also Readily Accessible). |
| Addition | An extension or increase in the <i>conditioned space</i> floor area or height of a building or structure. |
| Adiabatic | Building surfaces that do not lose heat due to similar temperatures on both sides of that surface, such as shared walls between multifamily units. |
| AFUE | <i>Annual Fuel Utilization Efficiency</i> . The ratio of annual output energy to annual input energy which includes any non-heating season pilot input loss, and for gas or oil-fired furnaces or boilers, does not include electrical energy. |
| Air Barrier | An air barrier is a durable assembly that blocks air flow between conditioned space and unconditioned space. Air barriers must be continuous, sealed at all joints, penetrations, and interruptions using durable sealants intended for such use and compatible with all adjacent materials, and able to resist pressures without displacement or damage. |
| Alteration | Any construction or renovation to an existing structure other than repair or addition. Also, a change in a mechanical system that involves an extension, addition or change to the arrangement, type or purpose of the original installation. |
| Approved | Approval by the <i>code official or other authority having jurisdiction</i> as a result of investigation and tests conducted by him or her, or by reason of accepted principles or tests by nationally recognized organizations. |
| Approved Agency | An established and recognized agency regularly engaged in conducting tests or furnishing inspection services, when such agency has been approved by the <i>code official or other authority having jurisdiction, where one exists</i> . |
| Automatic | Self-acting, operating by its own mechanism when actuated by some impersonal influence, as, for example, a change in current strength, pressure, temperature or mechanical configuration (see also Manual). |
| Average R-value | For a single building component with two different thermal values, it is possible to calculate a "weighted" or "average" R-value. See Appendix C.5 for instructions. |
| Base Code | The standard RBES Energy Code, as distinct from the higher stringency <i>Stretch Code</i> . |
| Basement Wall | A wall 50% or more below grade and enclosing <i>conditioned space</i> . |
| Basement Windows | Windows that are installed in concrete walls of basements, generally less than 10 square feet. |
| Basic Requirements | The set of fixed requirements applicable to all homes using the Prescriptive and Software methods of compliance. |
| Bathroom | A room containing a bathtub, shower, spa or similar bathing fixture. |
| Bedroom | A room or space 70 square feet or greater, with egress window and closet, used or intended to be used for sleeping. A "den," "library," "home office" with a closet, egress window, and 70 square feet or greater or other similar rooms shall count as a bedroom, but living rooms and foyers shall not. |
| Biomass | The vegetation removed from the forest, usually logging slash, small-diameter trees, tops, limbs, or trees. This includes wood logs, wood pellets and wood chips. |

Figure F-1: Walkout Basement Example

Wall A is more than 50% below grade (basement wall)
All others are 5% or more above grade (exterior walls)



| | |
|---------------------|--|
| Blower Door | A calibrated fan that temporarily fits in an exterior door which is used to test and measure building air leakage. Such a test is required to determine code compliance in every home and must be conducted by a certified air leakage tester, as determined by the Vermont Department of Public Service. |
| BTU | Abbreviation for British thermal unit, which is the quantity of heat required to raise the temperature of 1 pound (0.454 kg) of water 1°F (0.56°C), (1 Btu=1,055 J). It is about the equivalent amount of heat produced by burning a wooden match, end to end. |
| Builder | The general contractor or other person in charge of construction, who has the power to direct others with respect to the details to be observed in construction. |
| Building | Any structure used or intended for supporting or sheltering any use or occupancy, including any mechanical systems, service water heating systems and electric power and lighting systems located on the building site and supporting the building. |
| Building Envelope | The basement walls, exterior walls, floor, roof, and any other building element that encloses <i>conditioned space</i> . This boundary also includes the boundary between <i>conditioned space</i> and any exempt or unconditioned space. See Figures F-2 and F-3 below. |
| Building Site | A contiguous area of land that is under the ownership or control of one entity. |
| Ceiling | <p>Ceiling requirements apply to portions of the roof and/or ceiling through which heat flows. Ceiling components include the interior surface of flat ceilings below attics, the interior surface of cathedral or vaulted ceilings, the interior surface of dormers, and bay window roofs. Ceiling components do <i>not</i> include skylights, which are considered part of glazing. The ceiling requirements also apply to floors over outside air, including floor cantilevers, floors of an elevated home, and floors of overhangs (such as the floor above a recessed entryway or open carport).</p> <ul style="list-style-type: none"> ▫ Ceiling area should be measured from the exterior dimensions over the conditioned space (including the <i>sloped</i> area cathedral ceilings). ▫ Ceiling insulation that does not maintain a consistent R-value across the entire ceiling (including over the top of exterior walls) cannot be given full R-value credit. If a "raised truss" or other means of ensuring full insulation R-value over the top of exterior walls is not installed, you must install R-49 insulation. |
| Ceiling Flats | Horizontal portions of the building with unconditioned or exposed space above and conditioned space below. |
| Ceiling Slopes | Exterior portions of the building with unconditioned or exposed space above and with conditioned space below that are between 1° and 60° of horizontal. (See also Exterior Wall) |
| Code Official | The officer or other designated authority charged with the administration and enforcement of this code, or a duly authorized representative. The Department of Public Service is not the code official and shall not be required to conduct inspections of construction or construction documents. |
| Commercial Building | For this code, all buildings that are not included in the definition of "residential buildings", excluding mobile homes. |

Figure F-2: Building Envelope Example 1

The dark line delineates the building envelope. This illustration shows a house over a conditioned basement (i.e., no basement ceiling insulation), with a sun room over unconditioned crawl space (i.e., insulation in crawl space ceiling).

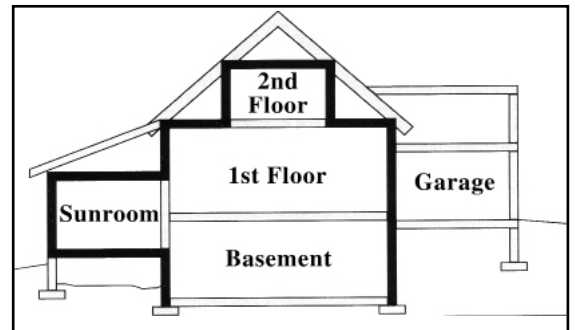
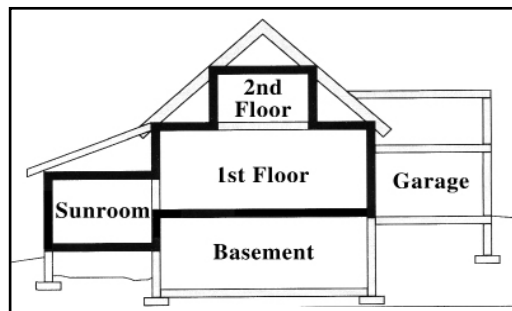


Figure F-3:

Building Envelope Example 2

This depicts the same house with an unconditioned basement (i.e., basement ceiling insulation). Note that the wall between sunroom and basement is included.



DRAFT

| | |
|--|--|
| Condensing Unit | A specific refrigerating machine combination for a given refrigerant, consisting of one or more power-driven compressors, condensers, liquid receivers (when required), and the regularly furnished accessories. |
| Conditioned Floor Area | The horizontal projection of the floors associated with the <i>conditioned space</i> . |
| Conditioned Space | An area, room or space that is enclosed within the building thermal envelope and that is directly or indirectly heated or cooled. Spaces are indirectly heated or cooled where they communicate through openings with conditioned spaces, where they are separated from conditioned spaces by uninsulated walls, floors or ceilings, or where they contain uninsulated ducts, piping or other sources of heating or cooling. |
| Continuous Air Barrier | A combination of materials and assemblies that restrict or prevent the passage of air through the building thermal envelope. |
| Continuous Insulation (ci) | Insulating material that is continuous across all structural members without thermal bridges other than fasteners and service openings. It is installed on the interior or exterior, or is integral to any opaque surface, of the building envelope. |
| COP | <i>Coefficient of Performance</i> . The ratio of the rate of heat delivered (or heat removed) to the rate of energy input, in consistent units, for a complete heat pump (or cooling) system under designated operating conditions. Do not consider supplemental heat when checking compliance with the heat pump equipment. A COP of 1.0 equals 100% efficient. |
| Covered Buildings | See Chapter 1 for complete definitions of buildings that are covered and not covered by the Residential Energy Code. |
| Crawl Space Wall | The opaque portion of a wall that encloses a crawl space and is partially or totally below grade. |
| Cubic Feet per Minute (CFM) | The quantity of air moved in 1 minute. A measurement typically applied to ventilation equipment. |
| Demand Recirculation Water System | A water distribution system where pump(s) prime the service hot water piping with heated water upon demand for hot water |
| Direct-Vent Appliances | Appliances that are constructed and installed so that all air for combustion is derived directly from the outside atmosphere and all flue gases are discharged directly to the outside atmosphere. |
| Doors | Doors include all openable opaque assemblies located in exterior walls of the building envelope. <i>If door is less than 50% glass:</i> Doors with less than 50% glass are treated as a single door assembly, in which case an average U-value (a U-value that includes both the glass and opaque area) must be used. <i>If door is more than 50% glass:</i> The entire opaque and glass areas of doors with more than 50% glass (i.e., sliding or patio doors) are considered glazing. If you have a decorative or other less energy-efficient door, you need not include that door in the U-value requirements for doors when using the Prescriptive method. The Residential Energy Code allows one door to be exempt when using either of these methods. |
| Duct | A tube or conduit utilized for conveying air. The air passages of self-contained systems are not to be construed as air ducts. |
| Duct System | A continuous passageway for the transmission of air that, in addition to ducts, includes duct fittings, dampers, plenums, fans and accessory air-handling equipment and appliances. |
| Dwelling Unit | A single housekeeping unit of one or more rooms providing complete, independent living facilities, including permanent provisions for living, sleeping, eating, cooking and sanitation. |
| EER | <i>Energy Efficiency Ratio</i> . The ratio of net equipment cooling capacity in Btu/hour to total rate of electric input in watts under designated operating conditions. When consistent units are used, this ratio becomes equal to COP (see also Coefficient of Performance). |
| Energy Factor | The seasonal efficiency rating (e.g., 0.61 "EF" or "Energy Factor") for domestic water heaters as determined by a standardized Department of Energy test procedure. |
| Energy Rating | A uniform method of ranking homes based on energy efficiency. Energy rating scores range from 0 to 100 points and 1 to 5 Stars Plus. Eighty points, the beginning of the 4 Star range, is considered "energy efficient." The Residential Energy Code allows an energy rating to be used to document compliance. See Chapter 7 for details. |
| Energy Recovery Ventilation System (ERV) | Systems that employ air-to-air heat exchangers to recover energy from exhaust air for the purpose of preheating, precooling, humidifying or dehumidifying outdoor ventilation air prior to supplying the air to a space, either directly or as part of an HVAC system. Moisture and heat are typically transferred from one air stream to another. |
| Exempt Buildings | See Chapter 1 for complete definitions of buildings that are covered and not covered by the Residential Energy Code. |
| Exterior Envelope | See Building Envelope. |

| | |
|--|--|
| Exterior Walls | Walls including both above-grade walls and basement walls. |
| Fenestration | Skylights, roof windows, vertical windows (fixed or moveable), opaque doors, glazed doors, glazed block and combination opaque/glazed doors. Fenestration includes products with glass and nonglass glazing materials. |
| Fenestration Product, Site Built | A fenestration designed to be made up of field-glazed or field-assembled units using specific factory cut or otherwise factory-formed framing and glazing units. Examples of site-built fenestration include storefront systems, curtain walls and atrium roof systems. |
| Floors | <p>Floors are considered individually for compliance purposes depending on their configuration and exposure:</p> <ul style="list-style-type: none"> ▮ Floors over “unconditioned spaces” (such as floors over an unheated garage, a vented crawl space, or an unconditioned basement) must be insulated. ▮ “Exposed” floors over outside air (such as floors of overhangs, cantilevers, and floors of an elevated home) must be insulated to the R-values of ceiling flats. ▮ Slab-on-grade floors of conditioned spaces must be insulated along the slab perimeter and are not required to be insulated underneath. ▮ Floors of basements and crawl spaces are not subject to an insulation requirement and do not have to be included as a building envelope component, even if the basement or crawl space is conditioned. In these cases, the walls must be insulated. ▮ Floors separating two conditioned spaces are not subject to an insulation requirement and do not have to be included as a building envelope component (although the band joist of these floors is considered part of the exterior walls for calculation purposes and is subject to the same R-value requirements). |
| Furnace, Warm Air | A self-contained, indirect-fired or electrically heated furnace that supplies heated air through ducts to spaces that require it. |
| Glazing | <p>Glazing is any translucent or transparent material in exterior openings of buildings (including windows, skylights, sliding glass doors, swinging/patio glass doors, basement windows and glass block). If a door has more than 50% glass (e.g., swinging or patio doors), it is considered part of the glazing area and not a “door.” If a door has less than 50% glass, the entire unit (opaque and glass areas) is defined as a “door.”</p> <ul style="list-style-type: none"> ▮ Windows in the exterior walls of <i>conditioned</i> basements (i.e., without ceiling insulation) <i>should</i> be included in the glazing-area calculations. Windows in walls of basements or crawl spaces with insulated ceilings are <i>not</i> included. Also be sure to include skylights in glazing area calculations and U-value requirements. ▮ Window U-value requirements for conditioned basements are treated separately from the rest of the glazing in the house under the Prescriptive method. |
| Glazing Area | The area of a glazing assembly is the interior surface area of the entire assembly, including glazing, sash, curbing, and other framing elements. The rough opening is also acceptable (for flat windows). |
| Glazing Percentage | The total glazing area divided by the gross wall area, then multiplied by 100. |
| Gross Wall Area | Includes the opaque area of above-grade walls, the opaque area of any individual wall of a conditioned basement more than 50% above grade (including the below-grade portions), all windows and doors (including windows and doors of conditioned basements), and the peripheral edges of floors (i.e., band joists). |
| Heat Pump | A refrigeration system that extracts heat from one substance and transfers it to another portion of the same substance or to a second substance at a higher temperature for a beneficial purpose. |
| Heat Recovery Ventilation System (HRV) | A factory-assembled device or combination of devices, including fans or blowers, designed to provide outdoor air for ventilation in which heat or heat and moisture is transferred between two isolated intake and exhaust air streams. |
| Heating Seasonal Performance Factor | (HSPF) The total heating output of a heat pump during its normal annual usage period for heating, in Btu's, divided by the total electric energy input during the same period, in watt hours, as determined by DOE 10 CFR Part 430, Subpart B, Test Procedures, and based on Region 4. |
| High-Efficacy Lamps | Light Emitting Diode (LED) or compact fluorescent lamps, T-8 or smaller diameter linear fluorescent lamps, or lamps with a minimum efficacy of not less than 65 lumens per watt; or light fixtures of not less than 55 lumens per watt. In determining the number or percent of lamps, each replaceable lamp (or light string) connected to a permanently installed lighting fixture shall count as one lamp. |
| Historic Building | <p>Any building or structure that is one or more of the following:</p> <ol style="list-style-type: none"> 1. Listed, or certified as eligible for listing by the State Historic Preservation Officer or the Keeper of the National Register of Historic Places, in the National Register of Historic Places. 2. Designated as historic under an applicable state or local law. 3. Certified as a contributing resource within a National Register-listed, state-designated or locally designated historic district |
| Home Energy Rating System (HERS) | See also "Energy Rating" . A home energy rating system accredited by the Vermont Public Service Department that provides a numerical rating in compliance with 21 V.S.A. §267(a). The purpose of this procedure is to ensure that accurate and |

| | |
|---|---|
| | consistent home energy ratings are performed by accredited HERS providers in Vermont and to promote an objective, cost-effective, sustainable home energy rating process as a compliance method for residential building energy codes; as qualification for energy programs designed to reach specific energy-saving goals; and as a way to provide Vermont's housing market the ability to differentiate residences based on their energy efficiency. |
| Hunting Camp | A seasonal building used as a temporary residence only during hunting season. |
| HVAC | Heating, ventilating and air conditioning. |
| HVAC System | The equipment, distribution network, and terminals that provide either collectively or individually the processes of heating, ventilating, or air conditioning to a building. <ul style="list-style-type: none"> ▫ Components: HVAC system components provide, in one or more factory-assembled packages, means for chilling or heating water, or both, with controlled temperature for delivery to terminal units serving the conditioned spaces of the building. Types of HVAC system components include, but are not limited to, water chiller packages, reciprocating condensing units and water source (hydronic) heat pumps (see also HVAC System Equipment). ▫ Equipment: HVAC system equipment provides, in one (single package) or more (split system) factory-assembled packages, means for air circulation, air cleaning, air cooling with controlled temperature and dehumidification and, optionally, either alone or in combination with a heating plant, the functions of heating and humidifying. The cooling function is either electrically or heat operated and the refrigerant condenser is air, water or evaporatively cooled. Where the equipment is provided in more than one package, the separate packages shall be designed by the manufacturer to be used together. The equipment shall be permitted to provide the heating function as a heat pump or by the use of electric or fossil-fuel-fired elements. (The word "equipment" used without a modifying adjective, in accordance with common industry usage, applies either to HVAC system equipment or HVAC system components.) |
| Infiltration | The uncontrolled inward air leakage into a building caused by the pressure effects of wind or the effect of differences in the indoor and outdoor air density or both. |
| Insulated Siding | A type of continuous insulation with manufacturer-installed insulating material as an integral part of the cladding product having a minimum R-value of R-2. |
| Level 1 Electric Vehicle Charging Station | Level 1 charging uses a standard 120V outlet. |
| Level 2 Electric Vehicle Charging Station | Level 2 uses a 240 volt AC charging. |
| Lighting | See "High-Efficacy Lamps/Lighting". |
| Log Home | A home in which the primary exterior walls are made of lengths of whole logs, one on top of the other, with the inside and outside surfaces the opposite sides of the same logs. |
| Local Ventilation | A mechanical ventilation system including fans, controls and ducts, dedicated to exhausting moisture-laden air to the outside of the building from the room or space in which the moisture is generated. |
| Manual | Capable of being operated by personal intervention (see also Automatic). |
| Mixed-Use | With respect to a structure that is three stories or less in height and is a mixed-use building that shares residential and commercial users, the term "residential building" must include the living spaces in the structure and the nonliving spaces in the structure that serve only the residential users such as common hallways, laundry facilities, residential management offices, community rooms, storage rooms, and foyers. (From Vermont 30 VSA § 51.) |
| Mobile Home | Homes subject to Title VI of the National Manufactured Housing Construction & Safety Standards Act of 1974 (i.e., single- and double-wide homes on a permanent chassis with detachable wheels). Mobile homes are exempt from the Residential Energy Code, but site-built components (e.g., conditioned basements or crawl spaces) must comply. |
| Manufactured Home | Factory-built modular homes that are <i>not</i> subject to Title VI of the National Manufactured Housing Construction & Safety Standards Act of 1974 (i.e., homes not on a permanent chassis). |
| Multifamily | A building containing three or more dwelling units. |
| Multiport | A whole-house ventilation system that has more than one exhaust or supply port inside the house. |
| NFPA | National Fire Protection Agency. Within the Residential Energy Code, NFPA 54 references the "Gas Code"; NFPA 31 references the "Oil Code." |
| Net Wall Area | Gross wall area minus the rough opening area of all glazing and doors. Also called the "opaque area." The net wall area includes the opaque wall area of all above-grade walls enclosing conditioned spaces, the opaque area of conditioned basement walls more than 50% above grade (including the below-grade portions), and peripheral edges of floors (i.e., band joists). The net wall area does <i>not</i> include windows, doors, or other such openings. |

| | |
|--|--|
| Nominal R-value | The R-value of an insulating material as listed on its packaging. |
| Occupancy | The purpose for which a building, or portion thereof, is utilized or occupied. |
| Occupancy Classifications | Residential Group R is the occupancy group used for buildings that include sleeping rooms and are not institutional and are not generally regulated by the International Residential Code. The IRC typically regulates single family homes and duplexes, any structure with more than two units is in the IRC. There are four different occupancy groups within R. Occupancy group R-1. is for transient uses like hotels, motels and boarding houses. Occupancy group R-2 is the group we see most often. It is for residences where occupants are primarily permanent. This includes apartments, dormitories, fraternities and sororities. It also includes vacation timeshares (again with more than two units) and convents and monasteries. Congregate living facilities with 16 or fewer occupants go into group R-3. R-3 is for permanent occupancies that aren't R-1, R-2, R-4 or I. These include buildings that are in the IRC but have no more than two units. Adult facilities and childcare facilities that provide accommodation for five or less people less than 24 hours a day are R-3. Where these facilities are in a single family home they must comply with the IRC. R-4 is for residential care/assisted living facilities including more than five and not more than 16 occupants. |
| Opaque Areas | All exposed areas of the building envelope which enclose conditioned space, except openings for windows, skylights, doors and building service systems. |
| Outdoor Air | Air taken from the outdoors and, therefore, not previously circulated through the building. |
| Owner-Builder | If all of the following apply: A. The owner of the residential construction is the builder, as defined under this chapter. B. The residential construction is used as a dwelling by the owner. C. The owner in fact directs the details of construction with regard to the installation of materials not in compliance with RBES. D. The owner discloses in writing to a prospective buyer, before entering into a binding purchase and sales agreement, with respect to the nature and extent of any noncompliance with RBES. Any statement or certificate given to a prospective buyer must itemize how the home does not comply with RBES, and must itemize which measures do not meet the RBES standards in effect at the time construction commenced. Any certificate must be recorded in the land records where the property is located, and sent to the Public Service Department, within 30 days following sale of the property by the owner. |
| Owner-Builder Disclosure Statement | The form that an owner-builder must complete — and disclose to a prospective buyer before entering into a binding purchase and sale agreement — if the home does not meet the technical requirement of the Vermont Residential Energy Code. The owner must complete this form (see Chapter 8), and file copies with the appropriate town clerk and the Public Service Department, within 30 days of construction completion. |
| Packaged Terminal Air Conditioner (PTAC) | A factory-selected wall sleeve and separate unencased combination of heating and cooling components, assemblies or sections (intended for mounting through the wall to serve a single room or zone). It includes heating capability by hot water, steam or electricity. |
| Packaged Terminal Heat Pump | A PTAC capable of using the refrigeration system in a reverse cycle or heat pump mode to provide heat. |
| Power-Vented Appliance | Appliances that operate with a positive vent static pressure (NFPA Category III) and utilize a mechanical fan to exhaust combustion gases from the appliance to the outside atmosphere. |
| Prescriptive Method | The easiest procedure for demonstrating compliance with the technical requirements of the Residential Energy Code. Homes must comply with all of the Basic Requirements in addition to one of the packages in the corresponding Prescriptive Requirements Table. See Chapter 5. |
| Prescriptive Requirements | The thermal (R-value and U-value) and heating efficiency (AFUE) values needed to meet the technical requirements of the Energy Code. |
| Primary Fuel | The fuel type that is used by the automatic heating system that is designed to provide heat to the majority of the building. Wood is never the primary fuel if there is another automatic heating system in place, regardless of the amount of heat it provides. |
| Primary Heating System | The automatic heating system that is designed to provide heat to the majority of the building. A wood system is never the primary heating system if there is another automatic heating system in place, regardless of the amount of heat it provides. |
| Raised Heel Truss | Any roof/ceiling construction that allows the insulation to achieve its full thickness or R-value over the top plate of exterior walls. Several constructions allow for this, including elevating the heel (sometimes referred to as an “energy truss,” “raised-heel truss” or “Arkansas truss”), use of cantilevered or oversized trusses, lowering the ceiling joists, framing with a raised rafter plate, or installing higher R-value insulation over the exterior wall top plates. See Figure B-1 for examples. |

| | |
|---|---|
| Rated Capacity | In terms of ventilation, the volume of air (in cfm) that the fan can move against a given static pressure (in inches or water gauge). Prescriptive compliance with the Vermont Residential Building Energy Standard requires that all fan capacities be rated at 0.1 inch (25 Pa) of water gauge. |
| Rated Design | A description of the proposed <i>building</i> used to determine the energy rating index. |
| RBES | Vermont Residential Building Energy Standards. |
| Readily Accessible | Capable of being reached quickly for operation, renewal or inspection without requiring those to whom ready access is requisite to climb over or remove obstacles or to resort to portable ladders or access equipment (see also Accessible). |
| RBES Certificate | See “Vermont RBES Certificate.” |
| Recovery Efficiency | For water heaters, the percent of energy consumed that is transferred to heat the water when the appliance is firing. Does not include stand-by or off-cycle losses (see also Energy Factor). |
| Renewable Energy | Means energy produced using a technology that relies on a resource that is being consumed at a harvest rate at or below its natural regeneration rate including, but not limited to solar hot water, solar hot air, solar photovoltaics, wind, and hydro. A. Methane gas and other flammable gases produced by the decay of sewage treatment plant wastes or landfill wastes and anaerobic digestion of agricultural products, byproducts, or wastes must be considered renewable energy resources, but no form of solid waste, other than agricultural or silvicultural waste, must be considered renewable. B. The only portion of electricity produced by a system of generating resources that must be considered renewable is that portion generated by a technology that qualifies as renewable. C. Technologies using the following fuels shall not be considered renewable energy supplies: coal, oil, propane, and natural gas. D. <i>Biomass</i> is considered renewable. |
| Reroofing | The process of recovering or replacing an existing <i>roof covering</i> . See “Roof recover” and “Roof replacement.” |
| REScheck™ | Computer software available from the Residential Energy Code Assistance Center that determines compliance with the technical requirements of the Residential Energy Code. See Chapter 6. |
| Residential Buildings | For this code, includes R-3 buildings, as well as R-2 and R-4 buildings three stories or fewer in height above grade. |
| Residential Construction | New construction of residential buildings, or the construction of residential additions, alterations, renovations, or repairs. |
| Roof Recover | The process of installing an additional <i>roof covering</i> over a prepared existing <i>roof covering</i> without removing the existing <i>roof covering</i> . |
| Roof Repair | Reconstruction or renewal of any part of an existing roof for the purposes of its maintenance. |
| Roof Replacement | The process of removing the existing <i>roof covering</i> , repairing any damaged substrate and installing a new <i>roof covering</i> . |
| Room Air Conditioner | An encased assembly designed as a unit for mounting in a window or through a wall, or as a console. It is designed primarily to provide free delivery of conditioned air to an enclosed space, room or zone. It includes a prime source of refrigeration for cooling and dehumidification and means for circulating and cleaning air, and shall be permitted to also include means for ventilating and heating. |
| R-value | The inverse of the time rate of heat flow through a body from one of its bounding surfaces to the other surface for a unit temperature difference between the two surfaces, under steady state conditions, per unit area ($h \cdot ft^2 \cdot ^\circ F/Btu$) [$m^2 \cdot K/W$]. |
| Seasonal Energy Efficiency Ratio (SEER) | The total cooling output of an air conditioner during its normal annual usage period for cooling, in Btu/hour, divided by the total electric energy input during the same period, in watt-hours, as determined by DOE 10 CFR Part 430, Subpart B, Test procedures. |
| Self-Certify | The act of certifying that a home complies with the Residential Energy Code through the following steps: 1) performing an analysis to determine if a home as planned will comply; 2) verifying that the home as built will comply; and 3) signing and filing the required documentation. |
| Service Systems | All energy-using systems in a building that are operated to provide services for the occupants or processes housed therein, including HVAC, service water heating, illumination, transportation, cooking or food preparation, laundering and similar functions. |

Service Water Heating

Supply of hot water for purposes other than comfort heating.

Single-Family Home

As defined by the Residential Energy Code, a single-family building is a detached one- or two-family (i.e., duplex) residential building. Log homes (see definition) are considered separately.

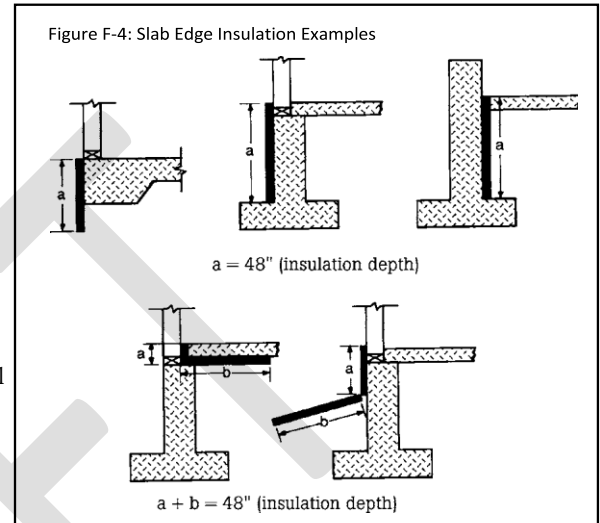
Skylight

Glass or other transparent or translucent glazing material installed at a slope of less than 60 degrees (1.05 rad) from horizontal.

Slab Edge

The perimeter of a slab-on-grade floor, where the top edge of the slab floor is above the finished grade or 12 inches or less below the finished grade. Insulation must be installed with the required R-value to a depth of at least 48" using any of the following configurations:

- † The slab insulation extends from the top of the slab downward.
- † The slab insulation extends from the top of the slab downward to the bottom of the slab and then horizontally underneath the slab for a minimum total distance of at least 48 inches.
- † The slab insulation extends from the top of the slab downward to the bottom of the slab and then horizontally away from the slab for a minimum total distance equal to at least 48 inches. The horizontal insulation must be covered by pavement or at least 10" of soil.
- † The top edge of insulation installed between the exterior wall and the interior slab can be cut at a 45 degree angle away from the exterior wall.



Sloped Ceiling

See "Ceiling Slopes."

Solar Heat Gain Coefficient (SHGC)

The ratio of the solar heat gain entering the space through the fenestration assembly to the incident solar radiation. Solar heat gain includes directly transmitted solar heat and absorbed solar radiation that is then reradiated, conducted or convected into the space.

Sone

A subjective unit of loudness for an average listener equal to the loudness of a 1,000-hertz (cycles per second) sound that has an intensity 40 decibels above the listener's own threshold of hearing.

Standard Truss

Any construction that does not permit the roof/ceiling insulation to achieve the required R-value over the exterior walls.

Stretch Code

A building energy code that achieves greater energy savings than the base RBES. The Stretch Code is required for Act 250 projects and may be adopted by municipalities.

Summer Camps

Residential buildings constructed for non-winter occupation with only a biomass (wood) or other on-site renewable heating system.

Sunroom

A one-story structure attached to a dwelling with a glazing area in excess of 40% of the gross area of the structure's exterior walls and roof.

System

A combination of central or terminal equipment or components or controls, accessories, interconnecting means and terminal devices by which energy is transformed so as to perform a specific function, such as HVAC, service water heating or illumination.

Thermal Isolation

Physical and space conditioning separation from *conditioned space(s)*. The *conditioned space(s)* shall be controlled as separate zones for heating and cooling or conditioned by separate equipment.

Thermal Resistance (R)

The reciprocal of thermal conductance ($h \cdot \text{ft}^2 \cdot ^\circ\text{F}/\text{Btu}$) [$(\text{m}^2 \cdot \text{K})/\text{W}$].

Overall Thermal Resistance (Ro): The reciprocal of overall thermal conductance ($h \cdot \text{ft}^2 \cdot ^\circ\text{F}/\text{Btu}$) [$(\text{m}^2 \cdot \text{K})/\text{W}$]. The overall thermal resistance of the gross area or individual component of the exterior building envelope (such as roof/ceiling, exterior wall, floor, crawl space wall, foundation, window, skylight, door, opaque wall, etc.), which includes the area-weighted R-values of the specific component assemblies (such as air film, insulation, drywall, framing, glazing, etc.).

Thermal Transmittance (U)

The coefficient of heat transmission (air to air). It is the time rate of heat flow per unit area and unit temperature difference between the warm-side and cold-side air films ($\text{Btu}/\text{hr} \cdot \text{ft}^2 \cdot ^\circ\text{F}$) [$\text{W}/(\text{m}^2 \cdot \text{K})$]. The U-factor applies to combinations of

different materials used in series along the heat flow path, single materials that comprise a building section, cavity airspaces and surface air films on both sides of a building element.

Overall Thermal Transmittance (Uo):

The overall (average) heat transmission of a gross area of the exterior building envelope (Btu/h · ft² · °F) [W/(m² · K)]. The Uo-factor applies to the combined effect of the time rate of heat flow through the various parallel paths, such as windows, doors and opaque construction areas, comprising the gross area of one or more exterior building components, such as walls, floors or roof/ceilings.

Thermostat

An automatic control device used to maintain temperature at a fixed or adjustable set point.

UA

Unconditioned Spaces

Unitary Cooling

Unusually Tight Construction

U-factor

Vapor Permeable Membrane

Vapor Retarder

Vapor Retarder Class

The U-value times the area of a building component.

from the house by insulated floors; and basements and crawl spaces with insulated ceilings.

One or more factory-made assemblies which include an evaporator or cooling coil, a compressor and condenser combination, and which shall be permitted to include a heating function as well. When heating and cooling equipment is provided in more than one assembly, the separate assemblies shall be designed to be used together.

Construction meeting the following requirements:

1. Storm windows or weatherstripping on openable windows and doors; and
2. Caulking or sealants applied to areas, such as joints around window and door frames, between sole plates and floors, between wall-ceiling joints, between wall panels, at penetrations for plumbing, electrical and gas lines, and at other openings; and
3. New buildings constructed in compliance with the RBES shall be considered built of unusually tight construction.

A measure of how well a material (or series of materials) conducts heat. U-factors for window and door assemblies are the reciprocal of the assembly R-value ($U=1/R$). Windows and doors are usually rated using U-factor rather than R-value. Lower numbers mean less heat loss and better performance. Equivalent to "U-factor."

A material or covering having a permeance rating of 5 perms ($2.9 \cdot 10^{-4} \text{ kg/Pa} \cdot \text{s} \cdot \text{m}^2$) or greater, when tested in accordance with the desiccant method using Procedure A of ASTM E 96. A vapor permeable material permits the passage of moisture vapor.

Spaces enclosed within buildings that do not fall under the definition of "conditioned space." For example: garages separated from the house by insulated walls and/or ceilings; attics separated

A vapor-resistant material, membrane or covering such as foil, plastic sheeting or insulation facing. Vapor retarders limit the amount of moisture vapor that passes through a material or wall assembly.

A measure of the ability of a material or assembly to limit the amount of moisture that

passes through that material or assembly. Vapor retarder class must be defined using the desiccant method with Procedure A of ASTM E96 as follows:

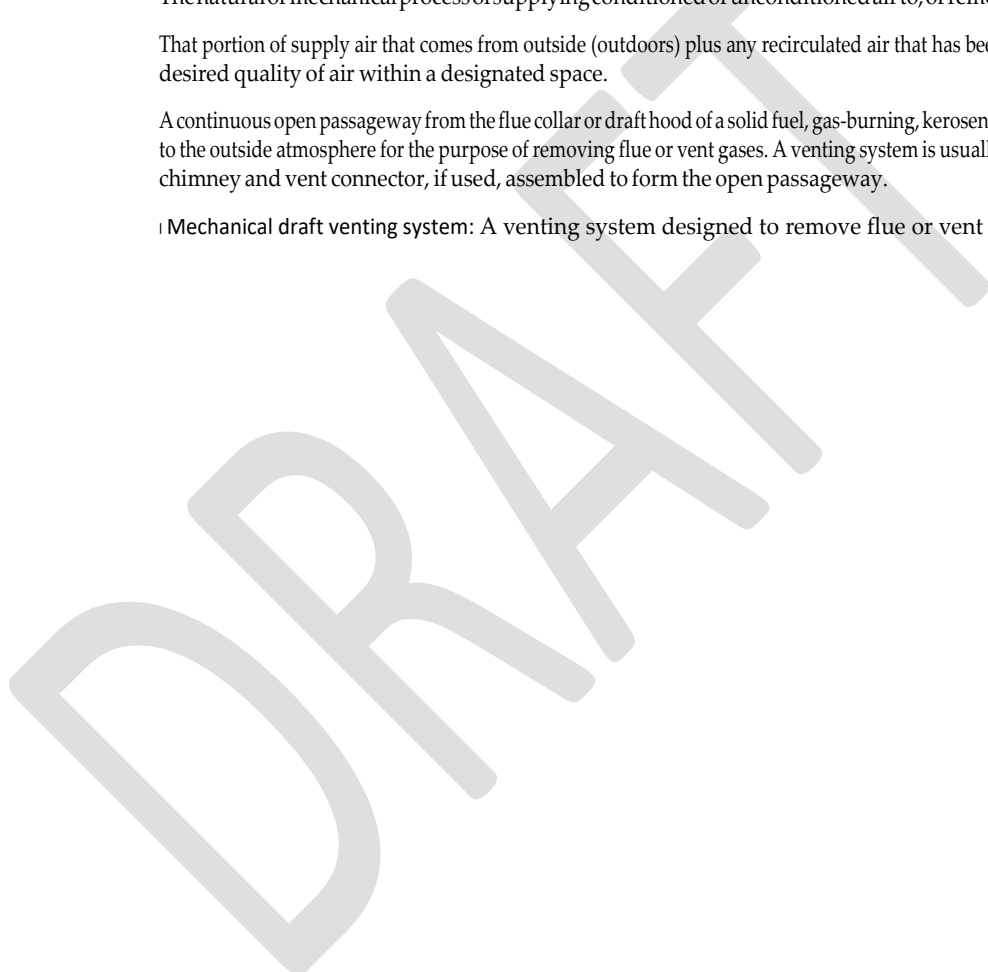
| Vapor Retarder Class ⁷ | Perm Rating (Dry Cup) | Description | Examples of Materials |
|-----------------------------------|-----------------------|--------------------------------------|---|
| Class I | 0.1 perm or less | Vapor impermeable or "Vapor Barrier" | Rubber membrane, sheet polyethylene, glass, foils |
| Class II | 0.1 - 1.0 perm | Vapor semi-impermeable | Oil-based paint, Kraft-faced batt, vinyl wall coverings, stucco |
| Class III | 1.0 – 10 perm | Vapor semi-permeable | Plywood, OSB, EPS, XPS, most latex paints, heavy asphalt-impregnated building paper, wood board sheathing |
| Vapor Open | >10 perm | Vapor permeable | Unpainted gypsum board, unfaced fiberglass, cellulose, many "housewraps" |

The natural or mechanical process of supplying conditioned or unconditioned air to, or removing such air from, any space.

That portion of supply air that comes from outside (outdoors) plus any recirculated air that has been treated to maintain the desired quality of air within a designated space.

A continuous open passageway from the flue collar or draft hood of a solid fuel, gas-burning, kerosene or oil-burning appliance to the outside atmosphere for the purpose of removing flue or vent gases. A venting system is usually composed of a vent or a chimney and vent connector, if used, assembled to form the open passageway.

▫ **Mechanical draft venting system:** A venting system designed to remove flue or vent gases by mechanical means, that



| | |
|---|---|
| | <p>consists of an induced draft portion under nonpositive static pressure or a forced draft portion under positive static pressure.</p> <ul style="list-style-type: none"> - Forced-draft or power venting system. A portion of a venting system using a fan or other mechanical means to cause the removal of flue or vent gases under positive static vent pressure. - Induced draft venting system. A portion of a venting system using a fan or other mechanical means to cause the removal of flue or vent gases under nonpositive static vent pressure. <p>† Natural draft venting system: A venting system designed to remove flue or vent gases under nonpositive static vent pressure entirely by natural draft.</p> <p>† Sealed combustion venting system: A venting system designed so that all air for combustion is derived directly from the outside atmosphere and all flue gases are discharged directly to the outside atmosphere.</p> |
| Vermont RBES Certificate | <p><i>Vermont Residential Building Energy Standards Certificate.</i> The one-page form that itemizes the energy components of a building and indicates its compliance with the Residential Energy Code. The builder must sign and affix this certificate to the property and provide one copy each to the local town clerk and the Public Service Department within 30 days of construction completion. See Chapter 8.</p> |
| Vertical Fenestration | <p>Windows (fixed or move-able), opaque doors, glazed doors, glazed block and combination opaque/glazed doors composed of glass or other transparent or translucent glazing materials and installed at a slope of a least 60 degrees (1.05 rad) from horizontal.</p> |
| Visible Transmittance (VT) | <p>The ratio of visible light entering the space through the fenestration product assembly to the incident visible light, Visible Transmittance, includes the effects of glazing material and frame and is expressed as a number between 0 and 1.</p> |
| Water Heater | <p>If a water heater is used as the primary means of heating a house, one of the Professional Services methods must be used to document compliance with the Code.</p> |
| Wood Stove | <p>If a wood stove is used as the primary means of heating a house, the HER compliance method (see Chapter 7) must be used to document compliance with the Energy Code.</p> |
| Whole House Mechanical Ventilation System | <p>An exhaust system, supply system, or combination thereof that is designed to mechanically exchange indoor air with outdoor air when operating continuously or through a programmed intermittent schedule to satisfy the whole house ventilation rates.</p> <p>† Whole-House Ventilation System, Single Port: A whole-house ventilation system that has only one connection to the conditioned space and one connection to outdoor air.</p> <p>† Whole-House Ventilation System, Supply Only: Supply-only systems provide outdoor air for ventilation via a single fan or multiple fans. Stale air may exhaust through typical leaks in the building envelope. Supply-only systems may pressurize the indoor environment.</p> <p>† Whole-House Ventilation System, Exhaust Only: Exhaust only systems exhaust stale indoor air via a single fan, multiple fans or the installation of dual-purpose fans (i.e., serving both localized and whole house ventilation functions). Fresh incoming air may be provided by installed inlet ports or from typical leaks in the building envelope. Exhaust only systems may depressurize the indoor environment.</p> <p>† Whole-House Ventilation System, Multi-Port: A whole house ventilation system that has more than one exhaust or supply port inside the house.</p> <p>† Whole-House Ventilation System, Single-Port: A whole house ventilation system that has only one connection to the conditioned space and one connection to outdoor air.</p> |
| Zone | <p>A space or group of spaces within a building with heating or cooling requirements that are sufficiently similar so that desired conditions can be maintained throughout using a single controlling device.</p> |